

MEDICAL
& PODIATRY

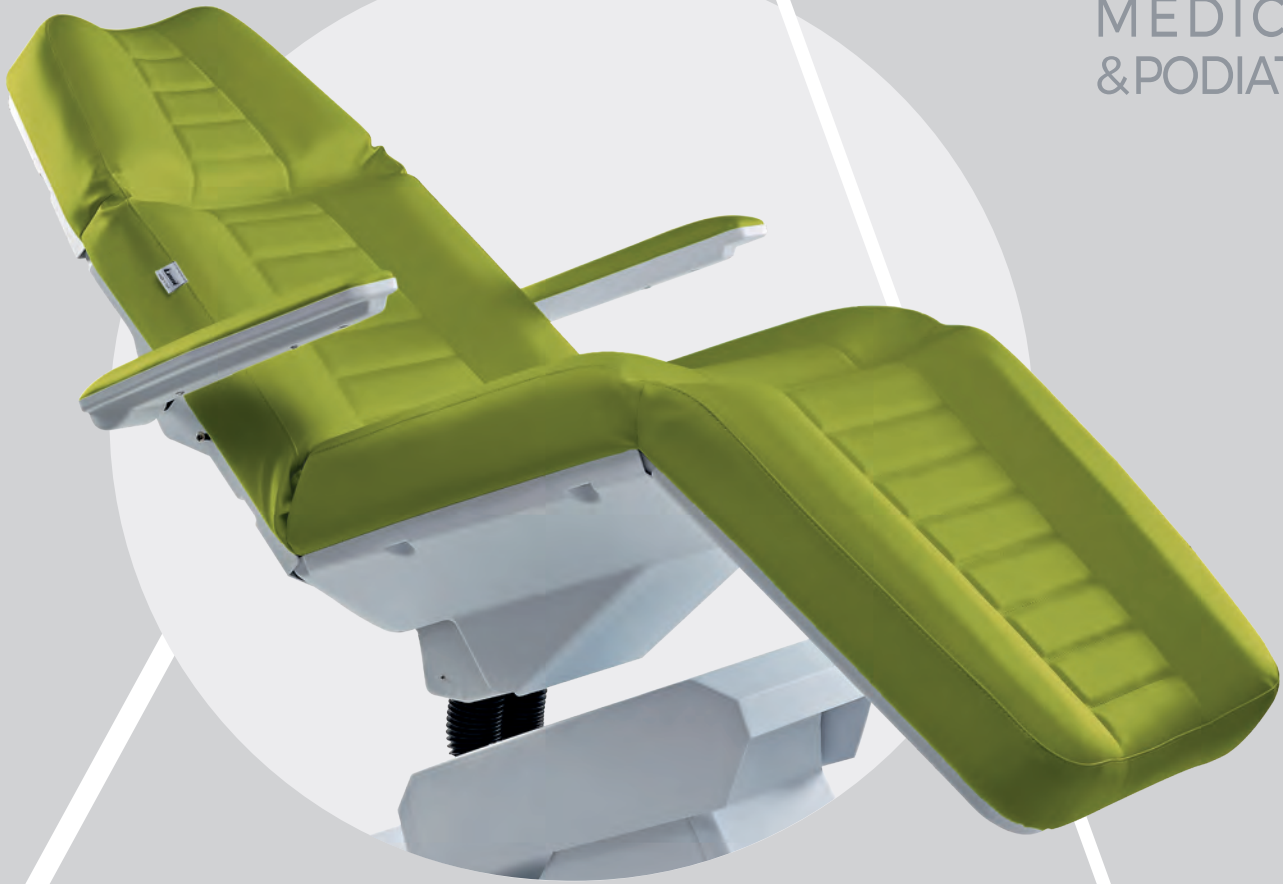

Lemi[®]
ITALIAN WELLNESS EQUIPMENT

MEDICAL
& PODIATRY
2022

Lemi[®]
ITALIAN WELLNESS EQUIPMENT



443.090.V



50 100 100 75



DEAR CUSTOMERS

Thank you for taking the time to explore the new LEMI catalogue.

Those of you who have been collaborating with us since the very beginning, as far back as 1989, know that we have always strived to offer the best products.

As forerunners, we have even sought to always anticipate the market's demands on numerous occasions, as well as satisfy your specific requirements.

After more than 30 years, this latest catalogue bears witness to our constant dedication and serves as an ideal tool for introducing our company.

In addition to the whole range of LEMI products you may be familiar with, herein you will also find the same spirit joining us throughout the years.

The same passion and expertise resulting into design and manufacture.

The same pursuit of excellence that distinguishes all Italian companies.

*That's what has been exciting us everyday **for 30 years.***

For this reason I want to share my story with you.

Thank you for choosing Lemi!

CARI CLIENTI

Grazie per il tempo che dedicherete al nuovo catalogo LEMI.

Chi ci conosce sa che da quando abbiamo iniziato, nell'ormai lontano 1989, abbiamo lavorato al vostro fianco per darvi i prodotti migliori.

A volte abbiamo osato, spesso siamo stati precursori, sempre abbiamo cercato di anticipare le richieste di mercato e soddisfare le vostre specifiche esigenze.

Al giorno d'oggi, **dopo più di 30 anni**, questo catalogo testimonia la strada che abbiamo percorso ed è lo strumento ideale per presentare la nostra azienda. Qui troverete tutti i prodotti LEMI che avrete ormai imparato a conoscere, ma anche lo spirito che ci unisce.

Quella stessa esperienza e passione da cui nascono la capacità di progettare e produrre.

Quella volontà di fare sempre il meglio che contraddistingue le aziende italiane.

È questo che ci emoziona ogni giorno **da 30 anni.**

Per questo motivo voglio condividere con voi la mia storia.

Grazie per aver scelto Lemi!



Emilio Brusaferrì
Lemi President

Emilio Brusaferrì
Presidente Lemi

1989



PROJECT

DESIGN

RESEARCH
& DEVELOPMENT

MECHANICAL
STRUCTURES

ELECTRONIC
COMPONENTS

UPHOLSTERY

1

2

3

4

5

6

PROGETTO

DESIGN

RICERCA
& SVILUPPO

STRUTTURE
MECCANICHE

COMPONENTI
ELETTRONICI

IMBOTTITURA

2022



ASSEMBLY

TESTING

MARKETING

COMMUNICATION

CONSULTING

AFTER SALES

7

8

9

10

11

12

MONTAGGIO

ANALISI

COMMERCIALIZZAZIONE

COMUNICAZIONE

CONSULENZA

POST VENDITA



THE COMPANY

LEMI has been manufacturing multifunctional chairs for medical and podiatry sectors since 1989.

The company was founded under the name of Brusaferrì & C. for the will of Emilio Brusaferrì and Silvio Genelli, cousins and close-knit friends who share the same passion for great challenges. Their persistence led to the development of Lemi 4:

- the very first treatment table with 4 electric motors, thus marking the beginnings of a true revolution in the medical sector.

It was the early 1990s and new wellness concepts were being combined with a spirit of creativity, initiative and passion for design, thus transforming the dream into a far-reaching enterprise.

Today, LEMI boasts a workforce of more than 60 employees and a production area of over 7.000 square meters, including two fully-equipped production facilities in Azzanello and Casalbuttano, in addition to over 1,000 square meters of offices space and a showroom of 500 square meters.

Thanks to its intensive research and development, as well as its continuous pursuit of new industrial paradigms, the company has now come to be recognized as one of the major players on the international scene. The company is renowned for its exceptional design, research, technology, quality, functionality, and meticulous finishing. These fundamental principles have resulted in the development of numerous products bearing the LEMI brand name as well as the unmistakable Italian craftsmanship worldwide.

L'AZIENDA

Dal 1989 LEMI produce poltrone multifunzionali per i settori medicale e podologico.

L'azienda viene fondata, col nome Brusaferrì & C., per volontà di Emilio Brusaferrì e Silvio Genelli, cugini e amici affiatati che condividono la passione per le grandi sfide. Dalla loro caparbia nasce Lemi 4:

- il primo lettino con 4 motori elettrici, che segna una vera rivoluzione nel settore medicale.

Siamo all'inizio degli anni '90 e i nuovi concetti di benessere uniti allo spirito di iniziativa, talento creativo e passione progettuale, trasformano il sogno in una grande realtà imprenditoriale.

Oggi LEMI conta oltre 60 persone impiegate, un'area produttiva di circa 7.000 mq nei due stabilimenti di Azzanello e Casalbuttano, 1.000 mq di uffici e uno showroom di 500 mq.

Si attesta come una delle aziende più significative del panorama internazionale e, grazie ad un'intensa attività di ricerca e sviluppo, continua ad imporre al settore nuovi paradigmi.

Design, ricerca, tecnologia, qualità, funzionalità, artigianalità e finiture accurate ne rappresentano i naturali punti di forza. Principi irrinunciabili per creare prodotti dallo stile inconfondibile che portano il marchio LEMI e l'autentico made in Italy nel mondo.

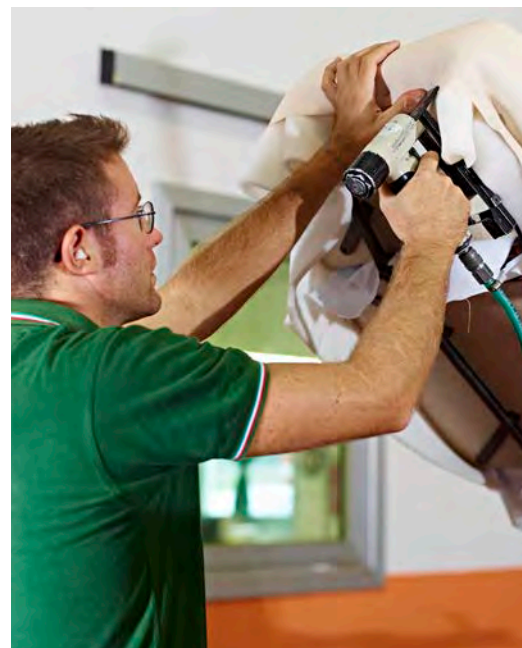

VALUES

LEMI puts among its values that of complying and even exceeding with customers' expectations. This is done by guaranteeing maximum precision in the construction of each single piece, as well as by ensuring continuous improvements, even with well-consolidated products. Thanks to its partnerships with numerous industry experts, the company is constantly welcoming new ideas, transforming them into innovative tools.

But LEMI's greatest assets lie in its staff, with all their experience, talent and passion. A wealth of knowledge and skill that has enriched day after day in the creative atmosphere of a youthful and dynamic environment.

I VALORI

LEMI pone tra i suoi valori quello di produrre nel rispetto del cliente, addirittura superando le aspettative. Lo fa costruendo con precisione estrema ogni singolo pezzo e apportando continui miglioramenti anche a prodotti consolidati. Grazie alla collaborazione con gli esperti del settore accoglie nuovi stimoli e li trasforma in strumenti innovativi.

Ma il valore più grande di LEMI sono le persone, la loro esperienza, il loro talento, la loro passione. Un patrimonio di conoscenza e competenza che si arricchisce giorno dopo giorno con la creatività di un ambiente giovane e dinamico.



SELECTION

The added values of excellent craftsmanship, maximum attention to detail, exceptional product quality and comprehensive service. For LEMI, these are just some of the basic requirements. They are the result of a winning strategy that's based upon the company's complete independence, the efficiency of an advanced R&D department and the decision not to outsource the production processes. From idea to design, from prototype to packaging, the product's entire life cycle is managed internally, with each single part being evaluated according to strict inspection criteria. Because our customers deserve nothing less than perfection.

LE SCELTE

Artigianalità come valore aggiunto, cura maniacale dei particolari, massima qualità del prodotto e totale efficienza nel servizio. Per LEMI sono solo alcune delle condizioni fondamentali. Sono il risultato di una strategia vincente basata sulla completa autonomia dell'azienda, sull'efficienza di un reparto di R&D all'avanguardia e sulla scelta di non delocalizzare la produzione. Dall'idea al progetto, dal prototipo all'imballo, l'intero ciclo di vita dei prodotti viene gestito internamente e ogni singolo pezzo valutato secondo severi criteri di controllo. Perché i clienti meritano solo la perfezione.

SERVICES

Personal wellness is a serious issue. That's why LEMI provides its distributors and its entire sales network with technical training to properly use equipment. Much emphasis is placed upon post-sales service, which LEMI sees as an essential part of the relation with clients.

All LEMI products come with an extended long warranty and, just in case, the company guarantees prompt intervention. Because as manufacturers, we understand the importance of preventing "downtime" and maintaining high quality standards.

I SERVIZI

Quando si tratta di benessere non si può scherzare. Per questo LEMI fornisce ai distributori e a tutta la rete vendita percorsi di formazione tecnica sull'utilizzo delle apparecchiature. Grande rilievo viene dato all'assistenza post vendita che per LEMI rappresenta un elemento indispensabile nel rapporto con il cliente.

Tutti i prodotti LEMI vengono rilasciati con garanzia di lunga durata e, in caso di guasto, l'azienda garantisce massima tempestività di intervento. Perché chi produce sa quanto sia importante non avere "fermi macchina" e mantenere elevati gli standard di qualità.



STYLE

All LEMI products feature a wide range of customization possibilities. A vast assortment of colors, materials, finishes making of each product a model unique.

All the padded models are hand-finished by LEMI's upholstery department, where our highly-skilled and experienced upholsterers constantly strive for perfection, creating extraordinary effects. It's a matter of style, the Italian style which is renowned worldwide.

LO STILE

Tutti i prodotti LEMI si caratterizzano per l'elevata personalizzazione. Una gamma completa di colori, materiali, finiture che rendono ogni modello unico.

Nel reparto tappezzeria di LEMI tutti i modelli imbottiti vengono rifiniti a mano. Solo grazie alla conoscenza e alla maestria dei tappezzieri si possono ottenere prodotti perfetti ed effetti straordinari. E' questione di stile, lo stile italiano che piace nel mondo.



50 100 100 75



443.090.V

CERTIFICATIONS

LEMI products quality is certified according to the ISO 9001 standard, with certificate number 50 100 100 75 issued by TUV Italy.

Furthermore, as an exclusive guarantee of its products' authenticity, LEMI even obtained the prestigious "100% Made in Italy" certification in 2010. This certification requires the company to undergo a series of inspections, in order to certify that its production cycle is entirely performed in Italy. All LEMI products come with a warranty certificate bearing a holographic, anti-counterfeit logo and sequential number, which allows the product to be tracked via a dedicated website. For our customers, this is a certified guarantee of superior quality. For LEMI, it's a calling.

LE CERTIFICAZIONI

La qualità dei prodotti LEMI è certificata ISO 9001 rilasciata da TUV Italia con certificato numero 50 100 100 75.

Dal 2010 LEMI ha ottenuto anche la prestigiosa certificazione del "100% Made in Italy", la sola che garantisce l'autenticità del prodotto. Significa essere sottoposti ad una serie di controlli molto accurati volti a certificare che l'intero ciclo produttivo sia totalmente realizzato in Italia. Tutti i prodotti LEMI vengono rilasciati completi di certificato di garanzia con marchio olografico anticounterfeiting e numerazione sequenziale, che permette di rintracciare il prodotto sul sito internet di riferimento. Per i clienti è garanzia di qualità superiore certificata da un marchio di tutela. Per LEMI è una vocazione.



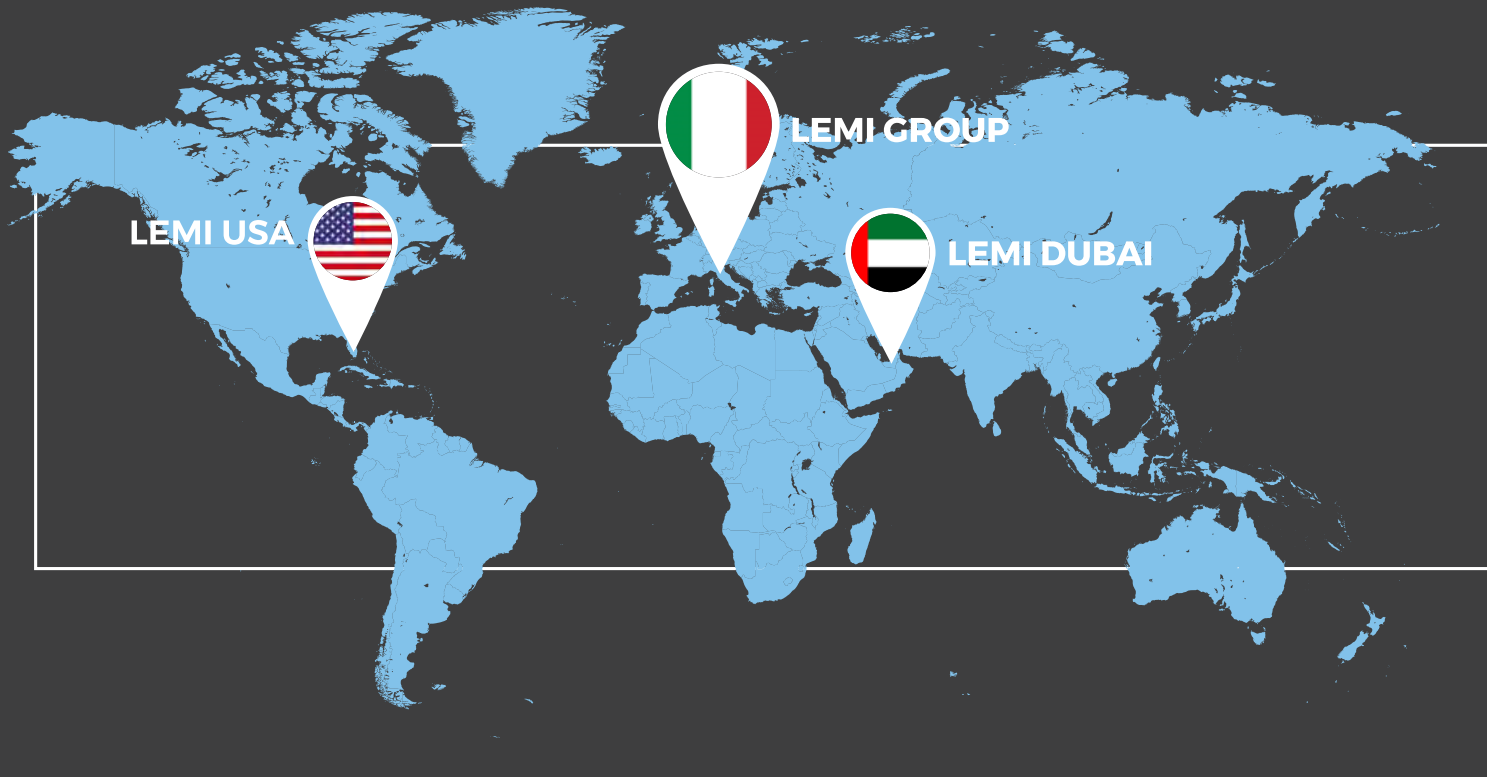

THE GLOBAL MARKET

LEMI brand can currently be found in over 100 countries worldwide. With its extensive network of distributors and sales representatives, the company is fully capable of satisfying the demands of the global markets, above all thanks to its innate ability to anticipate the industry's needs. LEMI is well-known for its high-end and technologically advanced products of unmistakable Italian style, which have attracted the patronage of a refined clientele.

Over 30 years since LEMI was set up, it has managed to reach important milestones, becoming a leader in Europe and, subsequently, growing to such an extent that it has won a leading position also on the Middle Eastern market with the establishment of LEMI Dubai office in 2015.

Over the past 5 years, LEMI has experienced significant growth both as a company and in terms of international relevance. This growth has paved the way for a corporate management capable of questioning its policy and pushing for embracing a new LEMI direct office.

However, some choices must be made at the right time and in a proper way.

That's why LEMI argued that in 2019 it was time to face a new challenge: after carrying out an adequate planning, it finally embarked on a new path by setting up a direct office in Miami (FL).

IL MERCATO GLOBALE

Il marchio LEMI è oggi presente in oltre 100 paesi nel mondo. Tramite una rete capillare di distributori e agenti rappresentanti, è in grado di soddisfare le esigenze dei mercati globali, grazie ad una innata capacità di anticipare le esigenze del settore. LEMI è apprezzata nel mondo per i suoi prodotti di fascia alta dalle elevatissime caratteristiche tecnologiche, con i quali conquista una clientela raffinata che apprezza e riconosce il vero stile italiano.

In 30 anni di storia aziendale LEMI è riuscita a raggiungere importanti traguardi, arrivando ad essere azienda Leader in Europa e, successivamente, crescendo fino ad arrivare ad essere leader anche nel mercato Middle East, dando vita nel 2015 all'ufficio LEMI Dubai.

Negli ultimi 5 anni LEMI ha vissuto un'importante crescita sia come realtà aziendale, sia come rilevanza a livello internazionale. Questa crescita ha fatto sì che la direzione cominciasse a interrogarsi e a orientarsi verso un'ottica di sviluppo di un nuovo ufficio diretto LEMI.

Ci sono però scelte che richiedono i tempi e le modalità giuste.

Per questo LEMI ha visto, nel 2019, il momento giusto per affrontare una nuova sfida: dopo un'adeguata preparazione, ha finalmente intrapreso un nuovo percorso aprendo un ufficio diretto a Miami (FL).

THE HEALTHY WAY

**“There is nothing permanent
except change.”
(Heraclitus)**

This was the thought of LEMI when choosing, in 2014, the way of sustainability. This is a long and challenging process that brings results only if pursued with seriousness. This is why LEMI did not stop but continued, embarking on a path of corporate growth that involved several aspects, aiming at a continuous improvement for both the people and the environment they work in.

LA VIA SOSTENIBILE

**“Non c'è nulla di immutabile,
tranne l'esigenza di cambiare.”
(Eraclito)**

Questo è stato il pensiero di LEMI quando, dal 2014, ha scelto la strada della sostenibilità. Si tratta di un processo lungo ed impegnativo che porta risultati solo se perseguito con serietà, ed è per questo che LEMI non si è fermata ma ha continuato, intraprendendo un percorso di crescita aziendale che ha coinvolto diversi aspetti, puntando ad un miglioramento continuo sia per le persone sia per l'ambiente in cui essere lavorano.



SOLAR PANELS

LEMI's plant is equipped with photovoltaic panels and LED lighting systems, thus improving its own impact on the environment, searching for clean energy consumption and creating a scale of value that is not based only on economic criteria. An example is the selection of new suppliers and new materials, such as FSC® certified wood, used for the production of most of treatment beds. In the same way, mattress coverings are free of synthetic colors and toxic materials, always respecting the environment.

PANNELLI SOLARI

Lo stabilimento LEMI è dotato di pannelli fotovoltaici e sistemi di illuminazione a led, migliorando il proprio impatto sull'ambiente, guardando ad un consumo di energia pulita, creando una scala di valore che non è basata solo sul criterio economico. Ne è un esempio la selezione di nuovi fornitori e nuovi materiali, quali i legni certificati con marchio FSC®, utilizzati per la produzione della maggior parte dei nostri lettini. Allo stesso modo, i rivestimenti dei materassi sono privi di coloranti sintetici e materiali tossici, sempre nel rispetto dell'ambiente.

PERSONAL WELLNESS

Straight to business improvement aimed at well-being, the already present area devoted to the GYM has recently been renewed. Employees can take advantage of a high-quality gym equipment at the end of the working day and during break times, to set up a personal fitness plan according to their needs. This allows people to enter the perspective of the importance of constant physical activity, which is often difficult to practice either because of one's own agenda or simply for lack of will.

LEMI has always highlighted the wellbeing of its employees. In 2017, a 10-minute break mid-morning and a 10-minute break mid-afternoon was institutionalized for all the team providing the opportunity to meet in a specific area inside the company, the warm and comfortable DINING AREA equipped with all necessary appliances. This modern space is also designed to have lunch, avoiding to stay in office or take one's own means to go out for lunch. This saves time and energy, besides providing benefits for health, as it is possible to share a common space and have lunch in peace, without having to constantly check the clock.

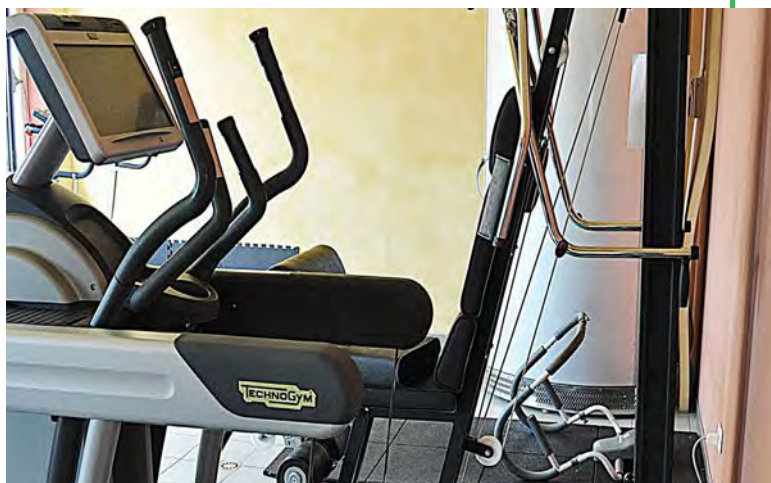

BENESSERE PERSONALE

Sempre nella visione di un miglioramento aziendale che punta al benessere, è stata recentemente rinnovata la già presente zona destinata alla PALESTRA. I dipendenti possono usufruire, dopo l'orario di lavoro e nei momenti di pausa, di apparecchiature di qualità per impostare un piano fitness personale secondo le proprie esigenze. Questo permette alle persone di entrare nell'ottica dell'importanza di un'attività fisica costante, che spesso è difficile mantenere sia per orari, impegni, o semplicemente per mancanza di volontà.

LEMI ha sempre messo in primo piano il benessere dei dipendenti. Nel 2017 ha istituzionalizzato una pausa di 10 minuti a metà mattina ed una pausa di 10 minuti a metà pomeriggio per tutti i lavoratori fornendo la possibilità di ritrovarsi in una zona apposita interna all'azienda, ovvero la DINING AREA ampia e luminosa, attrezzata con vari elettrodomestici. Si tratta di uno spazio completamente nuovo, pensato per offrire la possibilità di pranzare in azienda evitando di consumare il proprio pasto in ufficio, o di spostarsi con i propri mezzi per andare a pranzo. Si risparmiano così tempo ed energia e ne giova anche la salute, in quanto è possibile pranzare in tranquillità, senza dover controllare continuamente l'orologio e condividendo uno spazio comune.

PRODUCTS TIMELINE



LEMI 4
1989



PODO DREAM
2006



GYNO
PLUS
2012



2005
KE-TREAT



2010
DREAMED

We are what we make, and for that reason we always strive to do our best. Vibrant and vital, like the strings of a violin. Passionate about what we do, soloists in creation. Like a sounding board, we remain in constant harmony with the market. As both astute observers and innovative thinkers. Always on the lookout for concrete solutions.

Noi siamo ciò che produciamo, da sempre tesi a dare il meglio. Vibranti e vitali come le corde di un violino. Affiatati nel fare, solisti nel creare. Come una cassa armonica siamo in costante sintonia con il mercato. Osservatori attenti e portatori di cambiamento. Sempre in ascolto per dare risposte concrete.

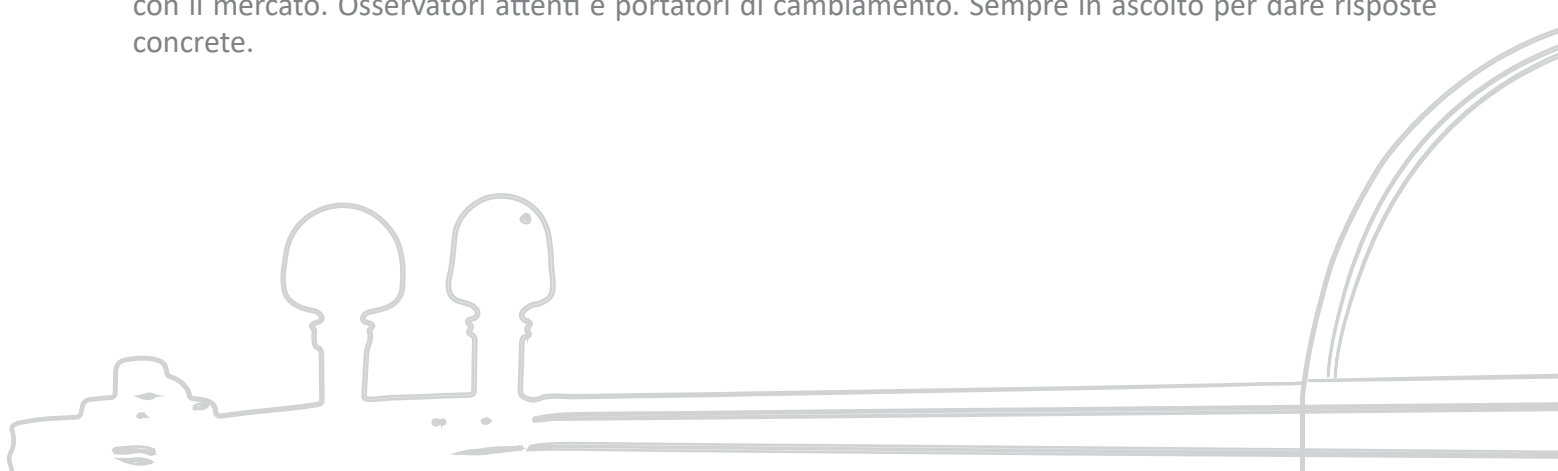

STORIA DEI PRODOTTI



HAIR
TECH
2014

... AND MORE
TO COME!
... E ALTRO
ANCORA!

2013

PODO 5



2017

DENTAMED
MOVE





MEDICAL



PODIATRY



STOOLS

AESTHETIC SURGERY / DERMATOLOGY
CHIRURGIA ESTETICA / DERMATOLOGIA

24

HEMODIALYSIS / BLOOD SAMPLING
EMODIALISI / PRELIEVI

64

CHEMOTHERAPY / ONCOLOGY
CHEMIOTERAPIA / ONCOLOGIA

80

ENT / OPHTHALMOLOGY / DENTISTRY
ORL / OFTALMOLOGIA / ODONTOIATRIA

90

TRICHOLOGY
TRICOLOGIA

120

GYNAECOLOGY
GINECOLOGIA

130

DIAGNOSTICS / PHYSIOTHERAPY
DIAGNOSTICA / FISIOTERAPIA

148

PODIATRY
PODOLOGIA

166

STOOLS
SGABELLI

202



MEDICAL



MEDICALE

LEMI MEDICAL Line comes from a constant strive to offer both the doctor and the patient ease of use and comfort, without sacrificing the elegance and design that distinguish our brand. Today, thousands of doctors choose LEMI products, which are the result of the cooperation with the sector specialists, research and innovation, meticulous choice of materials. Thanks to the wide customization of LEMI chairs, all the models can be custom-made according to the different sectors requirements to always ensure the best in terms of performances and results during the visit.

La linea MEDICALE LEMI è il frutto di una continua ricerca per offrire sia al medico che al paziente praticità e comfort, senza rinunciare all'eleganza e al design che contraddistinguono il nostro marchio. Oggi migliaia di medici scelgono i prodotti LEMI, risultato della collaborazione con gli specialisti del settore, di investimenti nella ricerca, di una scelta accurata dei materiali. Grazie all'ampia personalizzazione delle poltrone Lemi, tutti i modelli possono essere configurati in base alle necessità dei vari settori per garantire sempre il massimo in termini di prestazioni e risultati durante ogni tipo di visita.

INDEX INDICE

MULTIFUNCTIONAL

AESTHETIC SURGERY DERMATOLOGY

LEMI 4	26
LEMI 4 BI-ZAK	30
TESERA	34
LEMI SYNCRO BI-ZAK	38
LEMI 3	42
LEMI 3 BI-ZAK	46
LEMI 2	50
LEMI 2 BI-ZAK	54

HEMODIALYSIS BLOOD SAMPLING

LEMI MED	66
HE-MOVE	72

CHEMOTHERAPY ONCOLOGY

KE-TREAT	82
----------	----

ENT OPHTHALMOLOGY DENTISTRY

DREAMED	92
DREAMED MOVE	96
DREAMED ZAK	100
DREAMED ZAK MOVE	104
DENTAMED	108
DENTAMED MOVE	112

TRICHOLOGY

HAIR TECH	122
-----------	-----

GYNAECOLOGY

GYNO PLUS	132
GYNO	136
HYDROGYNO	140

DIAGNOSTICS PHYSIOTHERAPY

SOSUL	150
WELL	154
SOMED	158





AESTHETIC SURGERY
DERMATOLOGY

CHIRURGIA ESTETICA
DERMATOLOGIA



* M: Nefos 6

Version with anatomic mattress and flat armrests / Versione con materasso anatomico e braccioli automatici

Focus on

▪ **Standard handset control with 1 MEMORY function** **NEW**

- AUT function: automatic return to the original position (chair)
- SYNCHRO function: synchronized backrest/legrest movement (ONLY by handset control)
- Fire retardant class 1IM, "Azo" free, antibacterial, antifungal covering
- Entirely enclosed ABS casing
- Fully customizable

▪ **Standard version includes: 4 electric motors (height, back, leg, trendelenburg adjustment), handset control and a flat mattress**

▪ **Pulsantiera standard con 1 funzione MEMORIE** **NEW**

- Funzione AUT: ritorno automatico alla posizione base (poltrona)
- Funzione SYNCHRO: movimento schiena/gambe sincronizzato (SOLO con pulsantiera)
- Rivestimento ignifugo classe 1IM, "Azo" free, antibatterico, antimicotico
- Carter in ABS completamente chiuso
- Totalmente personalizzabile

▪ **La versione standard include: 4 motori elettrici (regolazione altezza, schienale, gamba, trendelenburg), pulsantiera e materasso piatto**

On demand

Examples of accessories available upon request at page 61

Esempi di accessori disponibili su richiesta a pagina 61

**COD. 851**

Lemi 4 is equipped with high-performance and silent electronics and a practical standard handset control. Wide mattress customization.

IDEAL FOR: diagnostics, check-up, dermatology and aesthetic surgery, gynecological examinations and blood sampling.

Lemi 4 è dotata di elettronica altamente performante e silenziosa e di una pratica pulsantiera standard. Ampia personalizzazione del materasso.

IDEALE PER: diagnostica, check-up, dermatologia e chirurgia estetica, esami ginecologici e prelievi.

Version without stitching / Versione senza cuciture



THE BED WHICH
30 YEARS AGO CHANGED
THE MEDICAL INDUSTRY

IL LETTINO CHE **30 ANNI FA**
RIVOLUZIONO' IL MONDO
MEDICALE

27

** The images are for illustrative purposes only and may not reflect the actual image of the finishing.*

** Le immagini hanno valore puramente illustrativo e possono non rispecchiare l'immagine reale della finitura.*

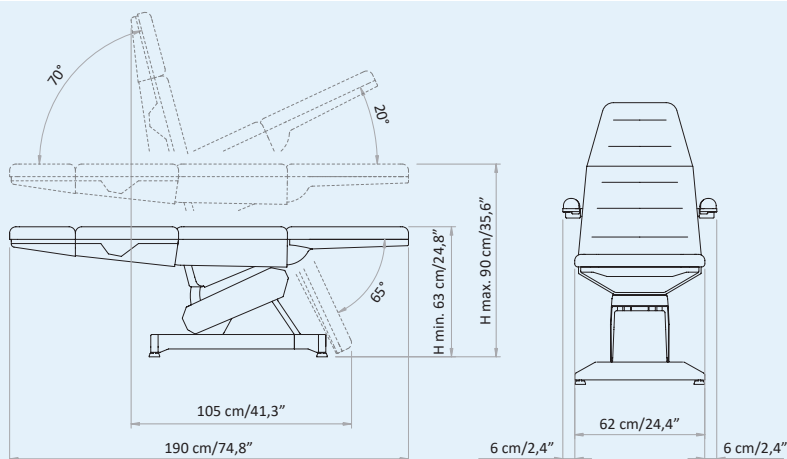
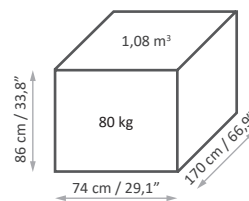
**Packaging details**

MAXIMUM CAPACITY
PORTATA MASSIMA

200 kg

STANDARD CONTROL



4 ELECTRIC MOTORS



M1 - MEMORY FUNCTION



AUT FUNCTION



SYNCHRO FUNCTION

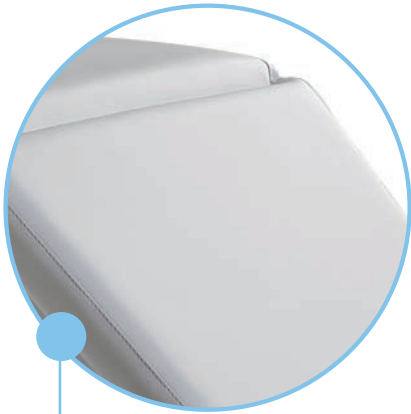

Version with flat mattress without stitching

Versione con materasso piatto senza cuciture

63-90 cm
(24,8"-35,6")

Electric height
Altezza elettrica



20°



Electric Trendelenburg
Trendelenburg elettrico

Version with flat mattress without stitching
Versione con materasso piatto senza cuciture

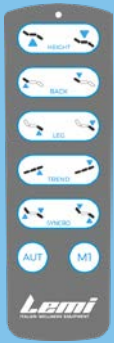

COMANDO STANDARD



4 MOTORI
ELETTRICI



M1 - FUNZIONE
MEMORIE



FUNZIONE
AUT



FUNZIONE
SYNCHRO

Synchronized backrest/legrest movement
Movimentazione sincronizzata schiena/gambe

ONLY by handset control
SOLO con pulsantiera

Electric backrest
Schiena elettrica

70°



Adjustable headrest
Testa regolabile

Electric legrest
Gambe elettriche

27°

65°

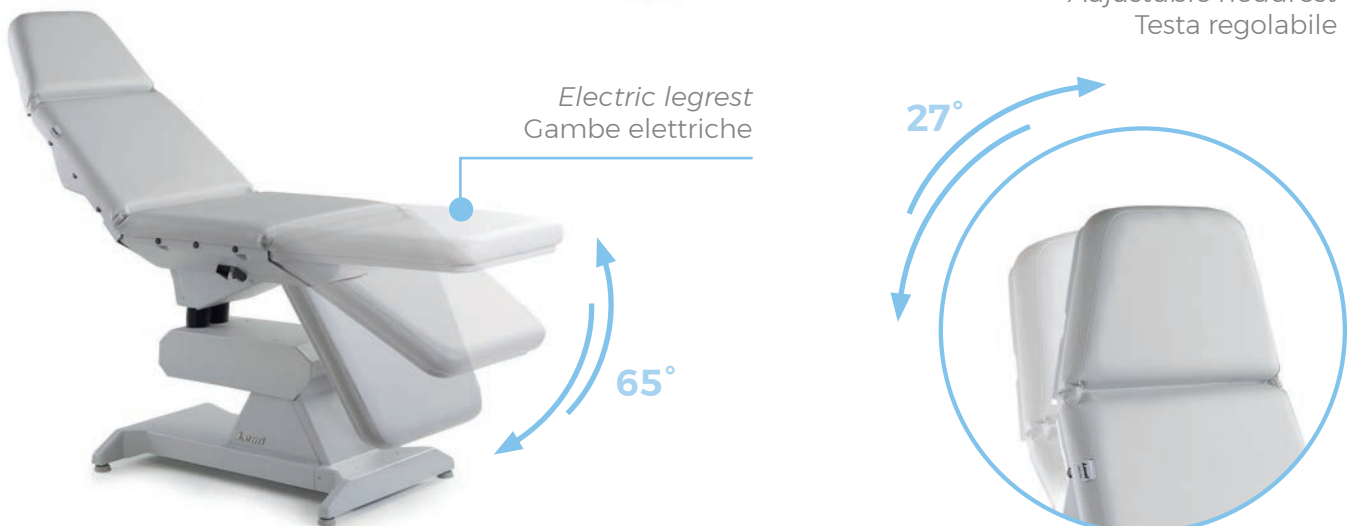

LEMI 4 BI-ZAK



30

* M: Nefos 6

Version with anatomic mattress and flat armrests / Versione con materasso anatomico e braccioli automatici

Focus on

- **Standard handset control with 1 MEMORY function** **NEW**
- **AUT function:** automatic return to the original position (chair)
- **SYNCHRO function:** synchronized backrest/legrest movement (ONLY by handset control)
- Fire retardant class 1IM, "Azo" free, antibacterial, antifungal covering
- Entirely enclosed ABS casing
- Fully customizable
- **Standard version includes: 4 electric motors (height, back, leg, trendelenburg adjustment), handset control and a Bi-Zak flat mattress (adjustable headrest and footrest)**

- **Pulsantiera standard con 1 funzione MEMORIE** **NEW**
- **Funzione AUT:** ritorno automatico alla posizione base (poltrona)
- **Funzione SYNCHRO:** movimento schiena/gambe sincronizzato (SOLO con pulsantiera)
- Rivestimento ignifugo classe 1IM, "Azo" free, antibatterico, antimicotico
- Carter in ABS completamente chiuso
- Totalmente personalizzabile
- **La versione standard include: 4 motori elettrici (regolazione altezza, schienale, gamba, trendelenburg), pulsantiera e materasso Bi-Zak piatto (testa e piedi regolabili)**

On demand

Examples of accessories available upon request at page 61

Esempi di accessori disponibili su richiesta a pagina 61



Adjustable footrest / Piede regolabile



Adjustable headrest / Testa regolabile

COD. 1139

Lemi 4 Bi-Zak is equipped with high-performance and silent electronics and a practical standard handset control. Bi-Zak mattress with wide customization.

IDEAL FOR: diagnostics, check-up, dermatology and aesthetic surgery, gynecological examinations and blood sampling.

Lemi 4 Bi-Zak è dotata di elettronica altamente performante e silenziosa e di una pratica pulsantiera standard. Materasso Bi-Zak con ampia possibilità di personalizzazione.

IDEALE PER: diagnostica, check-up, dermatologia e chirurgia estetica, esami ginecologici e prelievi.

** The images are for illustrative purposes only and may not reflect the actual image of the finishing.*

** Le immagini hanno valore puramente illustrativo e possono non rispecchiare l'immagine reale della finitura.*

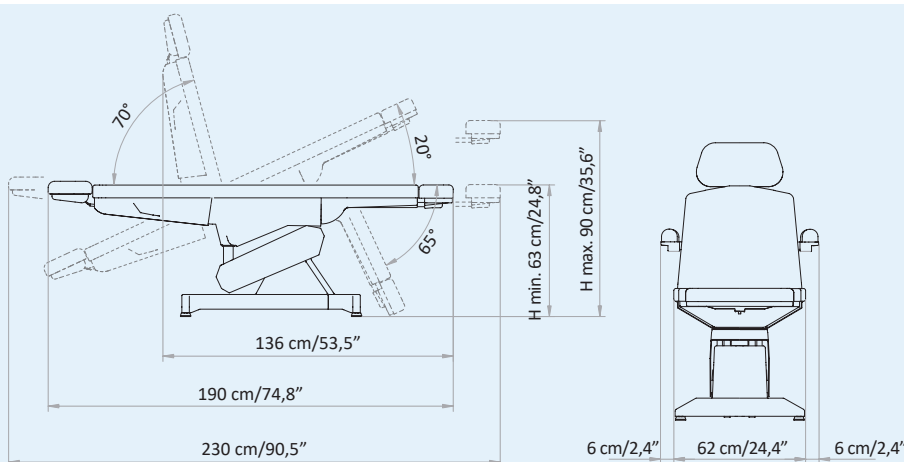

Packaging details

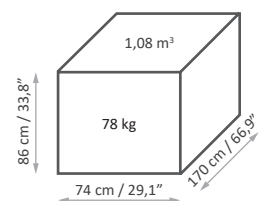

MAXIMUM CAPACITY
PORTATA MASSIMA

200 kg

STANDARD CONTROL

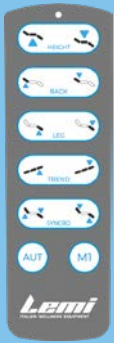

4 ELECTRIC MOTORS



M1 - MEMORY FUNCTION



AUT FUNCTION



SYNCHRO FUNCTION



Manually adjustable and removable Zak headrest

Testa Zak regolabile ed estraibile manualmente

63-90 cm
(24,8"-35,6")



Electric height
Altezza elettrica



Electric legrest
Gambe elettriche

65°

Version with anatomic mattress and flat armrests
Versione con materasso anatomico e braccioli automatici

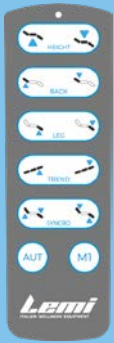

COMANDO STANDARD



4 MOTORI
ELETTRICI



M1 - FUNZIONE
MEMORIE



FUNZIONE
AUT



FUNZIONE
SYNCHRO



Electric backrest
Schiena elettrica

70°



Manually adjustable and
removable footrest

Piede regolabile ed
estraibile manualmente



Synchronized backrest/legrest movement
Movimentazione sincronizzata schiena/gambe

ONLY by handset control
SOLO con pulsantiera



34

* M: Nefos 6

Version with flat armrests / Versione con braccioli automatici

Focus on

- **Standard handset control with 1 MEMORY function** **NEW**
- **AUT function:** automatic return to the original position (chair)
- **SYNCHRO function:** synchronized backrest/legrest movement (ONLY by handset control)
- **Fire retardant class 1IM, "Azo" free, antibacterial, antifungal covering**
- **Entirely enclosed ABS casing**
- **Fully customizable**
- **Standard version includes: 4 electric motors (height, back, leg, trendelenburg adjustment), handset control and anatomic Bi-Zak mattress without stitching (adjustable headrest and footrest)**

- **Pulsantiera standard con 1 funzione MEMORIE** **NEW**
- **Funzione AUT:** ritorno automatico alla posizione base (poltrona)
- **Funzione SYNCHRO:** movimento schiena/gambe sincronizzato (SOLO con pulsantiera)
- **Rivestimento ignifugo classe 1IM, "Azo" free, antibatterico, antimicotico**
- **Carter in ABS completamente chiuso**
- **Totalmente personalizzabile**
- **La versione standard include: 4 motori elettrici (regolazione altezza, schienale, gamba, trendelenburg), pulsantiera e materasso anatomico Bi-Zak senza cuciture (testa e piedi regolabili)**

On demand

Examples of accessories available upon request at page 61

Esempi di accessori disponibili su richiesta a pagina 61

TESERA UPGRADE

COD. 1213

Tesera is equipped with high-performance and silent electronics and a practical standard handset control. Bi-Zak mattress with wide customization.

IDEAL FOR: diagnostics, check-up, dermatology and aesthetic surgery, pharmacy and dentistry.

Tesera è dotata di elettronica altamente performante e silenziosa e di una pratica pulsantiera standard. Materasso Bi-Zak con ampia possibilità di personalizzazione.

IDEALE PER: diagnostica, check-up, dermatologia e chirurgia estetica, farmacia e dentale.



Version with extra comfort mattress
Versione con materasso extra comfort

** The images are for illustrative purposes only and may not reflect the actual image of the finishing.*

** Le immagini hanno valore puramente illustrativo e possono non rispecchiare l'immagine reale della finitura.*

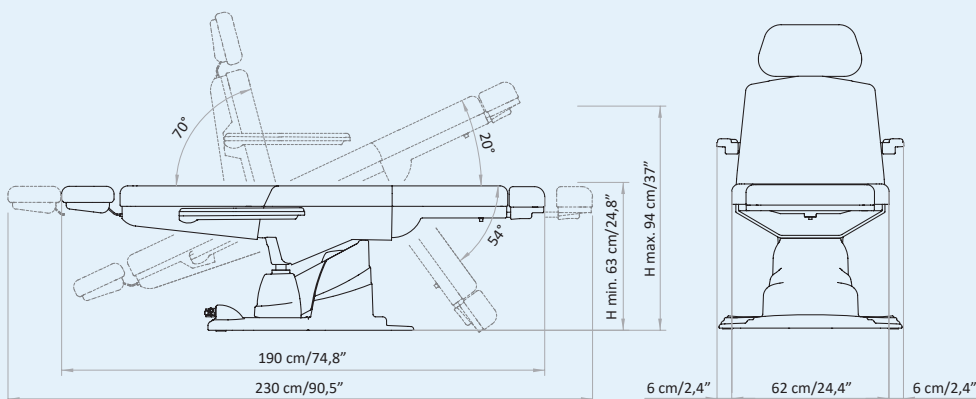

Packaging details

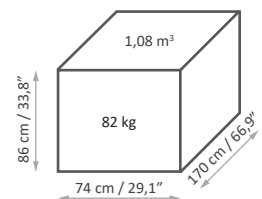

MAXIMUM CAPACITY
PORTATA MASSIMA

200 kg

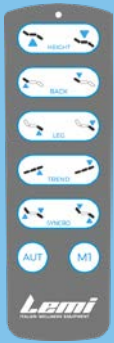

STANDARD CONTROL



4 ELECTRIC MOTORS



M1 - MEMORY FUNCTION



AUT FUNCTION



SYNCHRO FUNCTION



Removable headrest with manual adjustment

Testa estraibile con regolazione manuale

63-94 cm
(24,8"-37")



Electric height
Altezza elettrica



70°



Electric backrest
Schiena elettrica



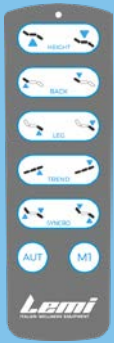

COMANDO STANDARD



4 MOTORI
ELETTRICI



M1 - FUNZIONE
MEMORIE



FUNZIONE
AUT



FUNZIONE
SYNCHRO

Synchronized backrest/legrest movement
Movimentazione sincronizzata schiena/gambe

ONLY by handset control
SOLO con pulsantiera



Electric Trendelenburg
Trendelenburg elettrico



Electric legrest
Gambe elettriche

LEMI SYNCRO BI-ZAK



38

* M: Nefos 1868

Version with anatomic mattress and flat armrests / Versione con materasso anatomico e braccioli automatici

Focus on

- Standard handset control with 2 MEMORY functions
- END function: automatic return to flat position (flat and minimum height)
- AUT function: automatic return to the original position (chair)
- Fire retardant class 1IM, "Azo" free, antibacterial, antifungal covering
- Entirely enclosed ABS casing
- Fully customizable
- Standard version includes: 3 electric motors for height, backrest-legrest (synchronized) and trendelenburg adjustment, foot pedal control and flat Bi-Zak mattress (adjustable headrest and footrest)

NEW

- Pedaliera standard con 2 funzioni MEMORIE
- Funzione END: ritorno automatico alla posizione piatta (piatto e altezza minima)
- Funzione AUT: ritorno automatico alla posizione base (poltrona)
- Rivestimento ignifugo classe 1IM, "Azo" free, antibatterico, antimicotico
- Carter in ABS completamente chiuso
- Totalmente personalizzabile
- La versione standard include: 3 motori elettrici per regolazione altezza, schienale-gamba (sincronizzate) e trendelenburg, pedaliera e materasso piatto Bi-Zak (testa e piedi regolabili)

NEW

On demand

Examples of accessories available upon request at page 61

Esempi di accessori disponibili su richiesta a pagina 61

LEMI SYNCRO BI-ZAK

UPGRADE



Adjustable footrest / Piede regolabile

COD. 1158

Lemi Syncro Bi-Zak is equipped with high-performance and silent electronics and a practical standard foot pedal control. Synchronized backrest/legrest movement. Bi-Zak mattress with wide customization.

IDEAL FOR: diagnostics, check-up, dermatology and aesthetic surgery, pharmacy and dentistry.

Lemi Syncro Bi-Zak è dotata di elettronica altamente performante e silenziosa e di una pratica pedaliera standard. Movimento sincronizzato schiena/gambe. Materasso Bi-Zak con ampia possibilità di personalizzazione.

IDEALE PER: diagnostica, check-up, dermatologia e chirurgia estetica, farmacia e dentale.

** The images are for illustrative purposes only and may not reflect the actual image of the finishing.*

** Le immagini hanno valore puramente illustrativo e possono non rispecchiare l'immagine reale della finitura.*

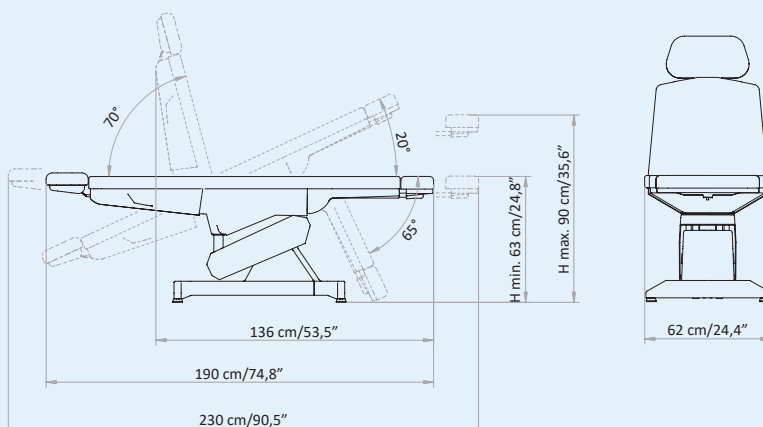

Packaging details

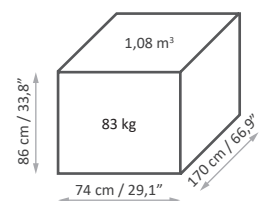

MAXIMUM CAPACITY
PORTATA MASSIMA

200 kg

STANDARD CONTROL

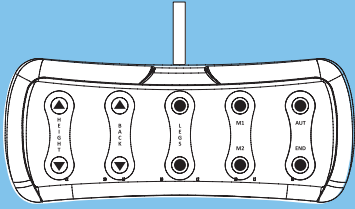

3M

3 ELECTRIC MOTORS

MEMORY

M1 - M2 MEMORY FUNCTION

AUT

AUT FUNCTION

END

END FUNCTION



Footrest with manual adjustment

Gamba estraibile con regolazione manuale

63-90 cm
(24,8"-35,6")

Electric height
Altezza elettrica



Synchronized backrest/legrest movement
Movimentazione sincronizzata schiena/gambe



COMANDO STANDARD

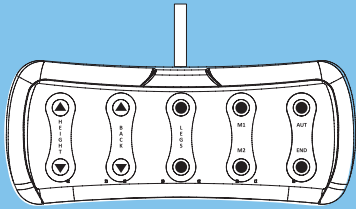

3 MOTORI
ELETTRICI



M1 - M2 FUNZIONI
MEMORIE



FUNZIONE
AUT



FUNZIONE
END



70°

Electric backrest
Schiena elettrica



*Manually adjustable and
removable Zak headrest*

Testa Zak regolabile ed
estraibile manualmente

Manual legrest adjustment
Gambe regolabili manualmente



65°



* M: Nefos 3962

Standard version / Versione standard

Focus on

▪ Standard foot pedal control

NEW

- Manual legrest, backrest and trendelenburg adjustment
- Fire retardant class 1IM, "Azo" free, antibacterial, antifungal covering
- Entirely enclosed ABS casing
- Fully customizable

▪ Standard version includes: 1 electric motor (height adjustment), foot pedal control and a flat mattress

▪ Pedaliera standard

NEW

- Regolazione manuale di gamba, schiena e trendelenburg
- Rivestimento ignifugo classe 1IM, "Azo" free, antibatterico, antimicotico
- Carter in ABS completamente chiuso
- Totalmente personalizzabile

▪ La versione standard include: 1 motore elettrico (regolazione altezza) pedaliera e materasso piatto

On demand

Examples of accessories available upon request at page 61

Esempi di accessori disponibili su richiesta a pagina 61

**COD. 1160**

Lemi 3 is equipped with high-performance and silent electronics and a practical standard foot pedal control. Wide mattress customization.

IDEAL FOR: diagnostics, check-up, dermatology and aesthetic surgery.

Lemi 3 è dotata di elettronica altamente performante e silenziosa e di una pratica pedaliera standard. Ampia personalizzazione del materasso.

IDEALE PER: diagnostica, check-up, dermatologia e chirurgia estetica.

* M: Nefos 6



** The images are for illustrative purposes only and may not reflect the actual image of the finishing.*

** Le immagini hanno valore puramente illustrativo e possono non rispecchiare l'immagine reale della finitura.*

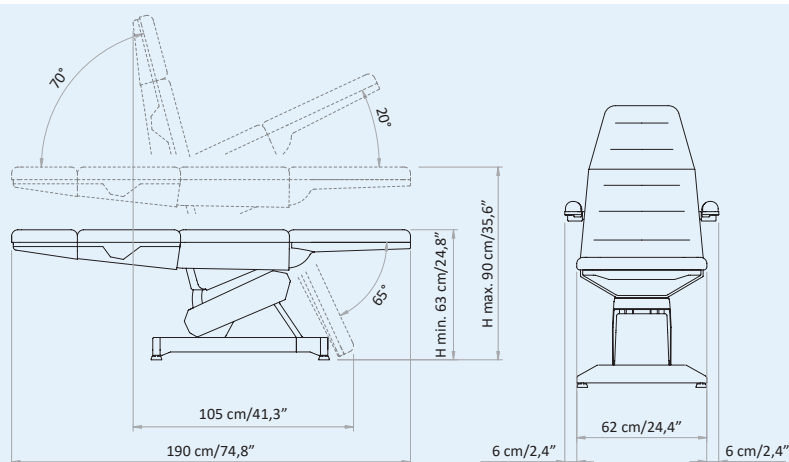
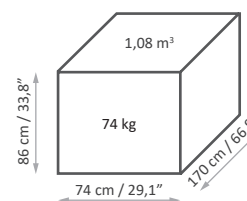
**Packaging details**

MAXIMUM CAPACITY
PORTATA MASSIMA

200 kg

STANDARD CONTROL

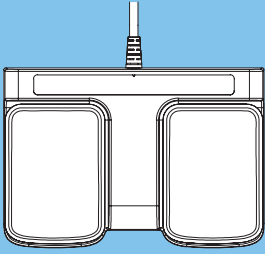

1 ELECTRIC
MOTOR



HIGH PERFORMANCE
SILENT ELECTRONICS



Flat mattress
Materasso piatto

63-90 cm
(24,8" - 35,6")

Electric height
Altezza elettrica



20°

Manual Trendelenburg
Trendelenburg manuale



STANDARD CONTROL

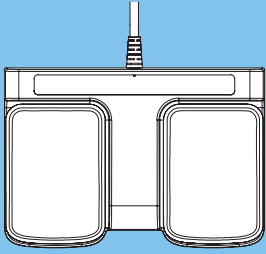

1 MOTORE
ELETTRICO



LETTRONICA ALTAMENTE
PERFORMANTE E SILENZIOSA



Manual legrest
Gamba manuale

65°

45

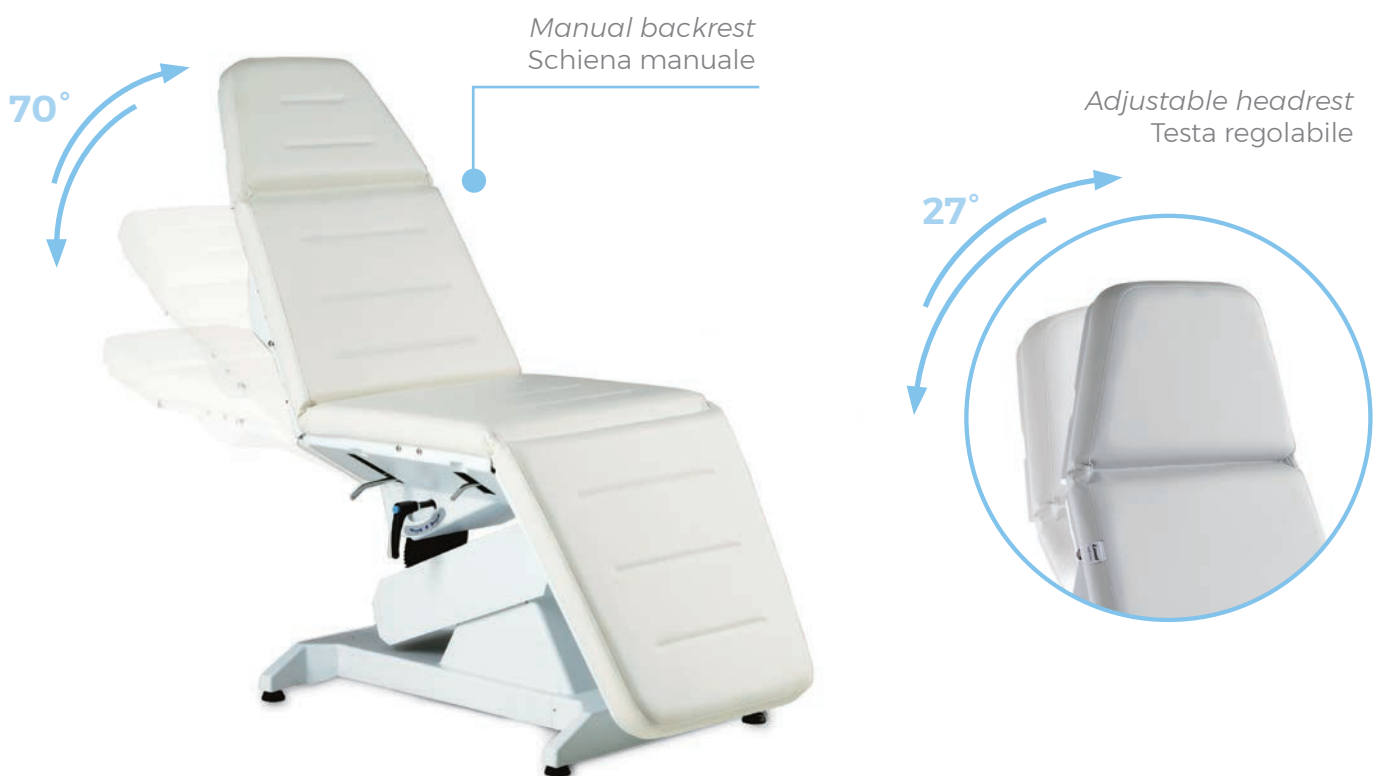

Manual backrest
Schiena manuale

70°

Adjustable headrest
Testa regolabile

27°

LEMI 3 BI-ZAK



46

* M: Nefos 8009

Version with anatomic mattress and flat armrests / Versione con materasso anatomico e braccioli automatici

Focus on

▪ Standard handset control

NEW

- Manual legrest, backrest and trendelenburg adjustment
- Fire retardant class 1IM, "Azo" free, antibacterial, antifungal covering
- Entirely enclosed ABS casing
- Fully customizable

▪ Standard version includes: 1 electric motor (height adjustment), handset control, Bi-Zak flat mattress (adjustable headrest and footrest)

▪ Pedaliera standard

NEW

- Regolazione manuale di gamba, schiena e trendelenburg
- Rivestimento ignifugo classe 1IM, "Azo" free, antibatterico, antimicotico
- Carter in ABS completamente chiuso
- Totalmente personalizzabile

▪ La versione standard include: 1 motore elettrico (regolazione altezza) pulsantiera, materasso Bi-Zak piatto (testa e piedi regolabili)

On demand

Examples of accessories available upon request at page 61

Esempi di accessori disponibili su richiesta a pagina 61



Adjustable footrest / Piede regolabile



Adjustable headrest / Testa regolabile

COD. 1161

Lemi 3 Bi-Zak is equipped with high-performance and silent electronics and a practical standard handset control. Bi-Zak mattress with wide customization.

IDEAL FOR: diagnostics, check-up, dermatology and aesthetic surgery.

Lemi 3 Bi-Zak è dotata di elettronica altamente performante e silenziosa e di una pratica pulsantiera standard. Materasso Bi-Zak con ampia possibilità di personalizzazione.

IDEALE PER: diagnostica, check-up, dermatologia e chirurgia estetica.

** The images are for illustrative purposes only and may not reflect the actual image of the finishing.*

** Le immagini hanno valore puramente illustrativo e possono non rispecchiare l'immagine reale della finitura.*

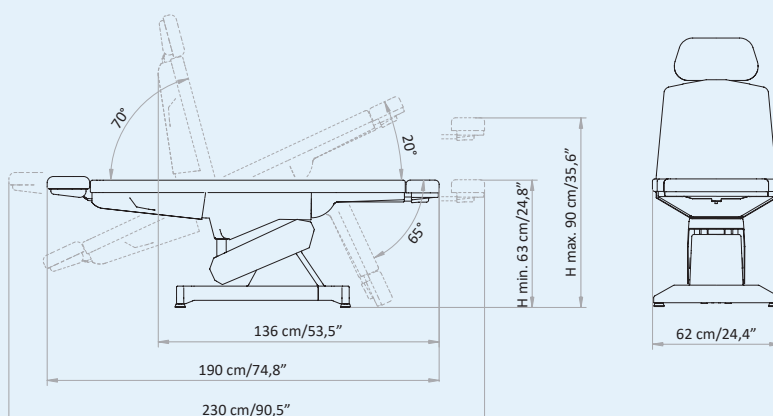

Packaging details

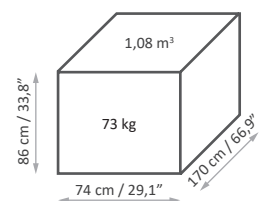

MAXIMUM CAPACITY
PORTATA MASSIMA



200 kg

STANDARD CONTROL

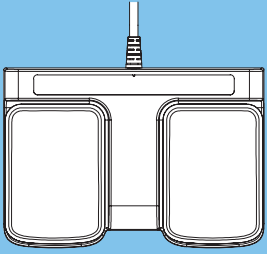

1 ELECTRIC
MOTOR



HIGH PERFORMANCE
SILENT ELECTRONICS



Manually adjustable and
removable Zak headrest

Testa Zak regolabile ed
estraibile manualmente

48

63-90 cm
(24,8"-35,6")

Electric height
Altezza elettrica



Manual Trendelenburg movement
Movimentazione Trendelenburg manuale



20°

Version with anatomic mattress and flat armrests
Versione con materasso anatomico e braccioli automatici

STANDARD CONTROL

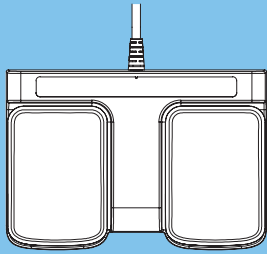

1 MOTORE
ELETTRICO



LETTRONICA ALTAMENTE
PERFORMANTE E SILENZIOSA



Manual backrest
Schiena manuale



*Manually adjustable and
removable footrest*

Piede regolabile ed
estraibile manualmente



Manual legrest
Gambe manuali



50

* M: Nefos 6986

Version with anatomic mattress and flat armrests / Versione con materasso anatomico e braccioli automatici

Focus on

- Hydraulic lift adjustment
- Manual legrest, backrest and trendelenburg adjustment
- Standard flat mattress
- Fire retardant class 1IM, "Azo" free, antibacterial, antifungal covering
- Entirely closed ABS casing
- 360° chair rotation
- Regolazione altezza con pompa idraulica
- Regolazione manuale di trendelenburg, schiena, gambe e testa
- Materasso piatto di serie
- Rivestimento ignifugo classe 1IM, "Azo" free, antibatterico, antimicotico
- Carter in ABS completamente chiuso
- Rotazione poltrona 360°

On demand

Examples of accessories available upon request at page 61

Esempi di accessori disponibili su richiesta a pagina 61

COD. 946

Lemi 2 is equipped with a hydraulic lift for height adjustment, while the legs, head and back are manually adjustable. 360° chair rotation. Wide mattress customization. Ideal for diagnostics, check-up, dermatology and aesthetic surgery

Lemi 2 è dotata di pompa idraulica per la regolazione dell'altezza, mentre gambe, testa e schiena sono regolabili manualmente. Rotazione poltrona 360°. Ampia personalizzazione del materasso. Ideale per diagnostica, check-up, dermatologia e chirurgia estetica.



** The images are for illustrative purposes only and may not reflect the actual image of the finishing.*

** Le immagini hanno valore puramente illustrativo e possono non rispecchiare l'immagine reale della finitura.*

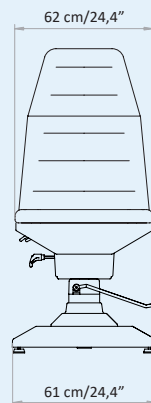
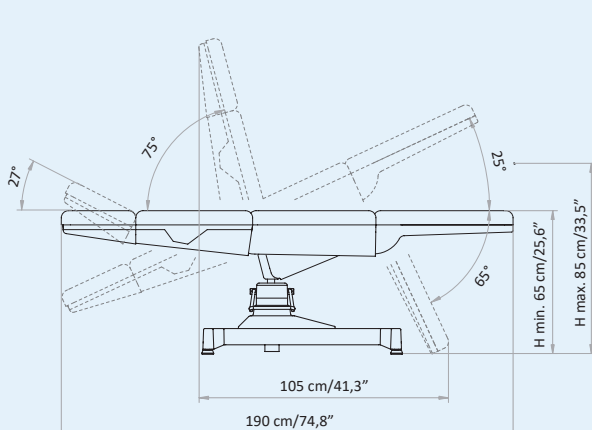

Packaging details

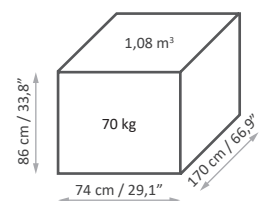

MAXIMUM CAPACITY
PORTATA MASSIMA



150 kg

MOVEMENTS

1 movement by hydraulic lift: height

4 manual movements: backrest, legrest, trendelenburg, headrest adjustment

Chair rotation 360°



Hydraulic lift
Pompa idraulica

65-85 cm
(25,6" - 33,5")

Height adjustment by hydraulic lift
Regolazione altezza con pompa idraulica



25°



Manual Trendelenburg
Trendelenburg manuale

360°



180° rotation on both sides
Rotazione 180° da entrambi i lati

MOVIMENTI

1 movimento con pompa idraulica: altezza

4 movimenti manuali: schiena, gambe, trendelenburg, inclinazione testa

Rotazione poltrona 360°

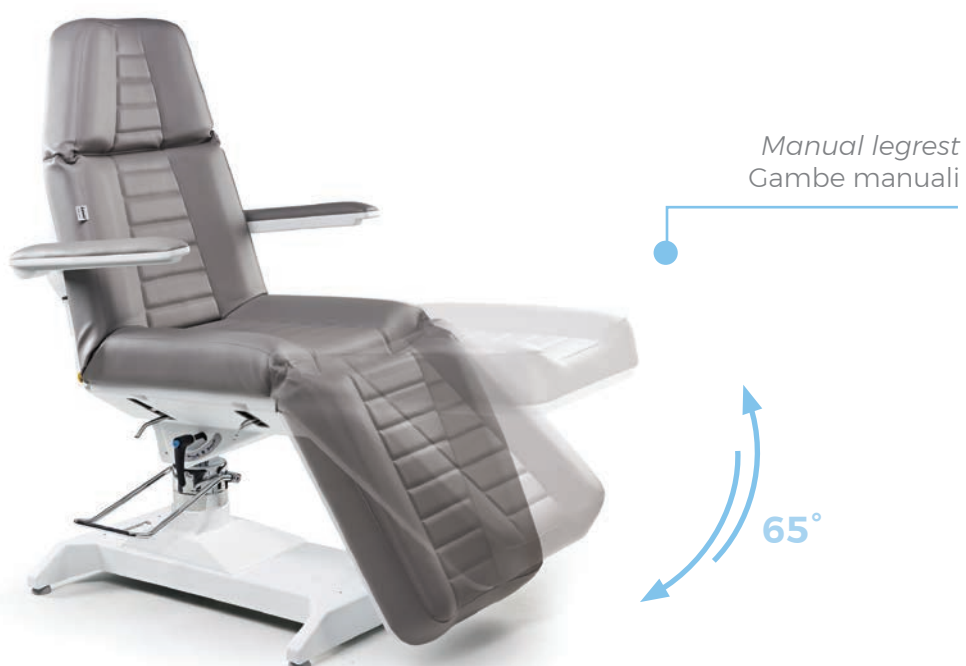

Version with anatomic mattress and flat armrests
Versione con materasso anatomico e braccioli automatici

LEMI 2 BI-ZAK



54

* M: Nefos 6

Version with Bi-Zak anatomic mattress / Versione con materasso anatomico Bi-Zak

Focus on

- Hydraulic lift adjustment
- Manual legrest, backrest and trendelenburg adjustment
- Standard Bi-Zak flat mattress (adjustable headrest and footrest)
- Fire retardant class 1IM, "Azo" free, antibacterial, antifungal covering
- Entirely closed ABS casing
- 360° rotation
- Regolazione altezza con pompa idraulica
- Regolazione manuale di trendelenburg, schiena, gambe e testa
- Materasso standard Bi-Zak piatto (testa e piedi regolabili)
- Rivestimento ignifugo classe 1IM, "Azo" free, antibatterico, antimicotico
- Carter in ABS completamente chiuso
- Rotazione 360°

On demand

Examples of accessories available upon request at page 61

Esempi di accessori disponibili su richiesta a pagina 61



Adjustable footrest / Piede regolabile



Adjustable headrest / Testa regolabile

COD. 955

Featuring a reliable hydraulic lift and manually adjustable, with 360° rotation. Standard Bi-Zak mattress (adjustable headrest and footrest) fully customizable. Ideal for diagnostics, check-up, dermatology and aesthetic surgery.

Dotato di pompa idraulica e regolabile manualmente, con rotazione a 360°. Materasso standard Bi-Zak (testa e piedi regolabili) totalmente personalizzabile. Ideale per diagnostica, check-up, dermatologia e chirurgia estetica.

** The images are for illustrative purposes only and may not reflect the actual image of the finishing.*

** Le immagini hanno valore puramente illustrativo e possono non rispecchiare l'immagine reale della finitura.*

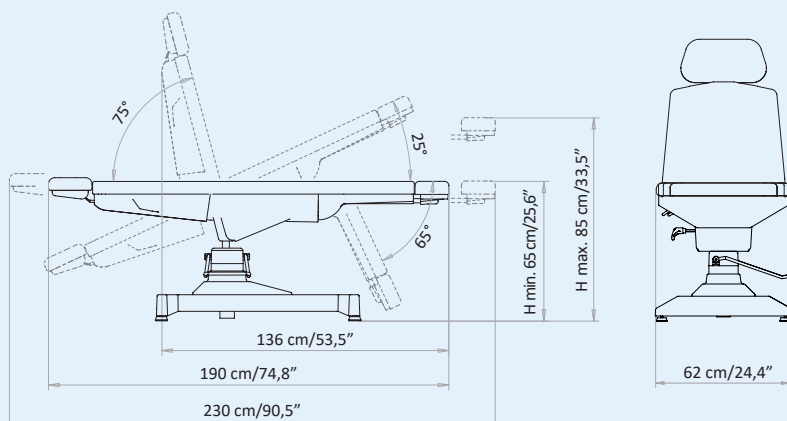

Packaging details

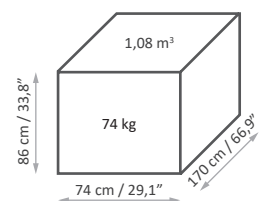

MAXIMUM CAPACITY
PORTATA MASSIMA

150 kg

HEMODIALYSIS BLOOD SAMPLING EMODIALISI LEMI 2 BI-ZAK PRELIEVI

x1



Rollholder
Portarotolo

x2



Blood sample taking armrests
(couple)
Braccioli da prelievo
(coppia)

56

Seat guides (couple)
Guide seduta (coppia)



x2



Fixed clamp (couple)
Morsetti fissi (coppia)

x2

x1



NEW

Hemo foot support
Supporto piede Hemo

GYNAECOLOGY GINECOLOGIA LEMI 2 BI-ZAK



x2

Thigh support
(couple)

Reggicose
(coppia)

57



Fixed clamp
(couple)

Morsetti fissi
(coppia)



x2

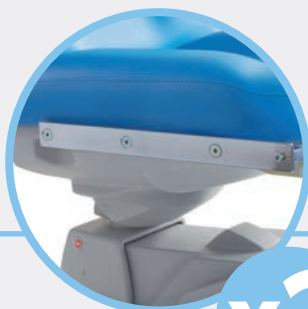

Seat guides (couple)
Guide seduta (coppia)

x2

MOVEMENTS

1 movement by hydraulic lift: height

5 manual movements: backrest, legrest, trendelenburg, adjustable and removable headrest and footrest

Chair rotation 360°



Manually adjustable and removable Zak headrest

Testa Zak regolabile ed estraibile manualmente

65-85 cm
(25,6" - 33,5")



Height by hydraulic lift
Altezza con pompa idraulica



Manual Trendelenburg movement
Movimentazione Trendelenburg manuale



Version with anatomic mattress and flat armrests
Versione con materasso anatomico e braccioli automatici

MOVIMENTI

1 movimento con pompa idraulica: altezza

5 movimenti manuali: schiena, gambe, trendelenburg, testa e piede regolabili ed estraibili

Rotazione poltrona 360°



Manually adjustable and
removable footrest

Piede regolabile ed
estraibile manualmente



LEMI STANDARD

Choose the medical chair with STANDARD CONFIGURATION by LEMI
Scegli la poltrona medica con la CONFIGURAZIONE STANDARD by LEMI

LEMI 4 BI-ZAK



ZAK HEADREST TESTA ZAK

Adjustable and removable Zak headrest
Testa Zak regolabile ed estraibile

FLAT MATTRESS MATERASSO PIATTO

Standard Bi-Zak flat mattress
Materasso standard Bi-Zak piatto

REMOVABLE FOOTREST PIEDE ESTRAIBILE

Adjustable and removable footrest
Supporto piede regolabile ed estraibile

HANDSET CONTROL PULSANTIERA

Practical handset control for chair adjustment
Pratica pulsantiera per regolazione poltrona

ACCESSORIES UPON REQUEST ACCESSORI SU RICHIESTA

Customize the medical chair with the ACCESSORIES available on request.
Personalizza la poltrona medica con gli ACCESSORI disponibili su richiesta.

HEADS TESTE



Small Zak headrest (only for Bi-Zak)
Testa Zak piccola (solo per Bi-Zak)



Strip headrest (only for Bi-Zak)
Testa strip (solo per Bi-Zak)



Anto headrest for hair transplant
(only for Bi-Zak)
Testa Anto per trapianto capelli
(solo per Bi-Zak)

MATTRESSES MATERASSI



Anatomic mattress
Materasso anatomico



Option Mattress without stitching
Opzione Materasso senza cuciture



Extra comfort mattress with Memory Foam
Materasso extra comfort con Memory Foam

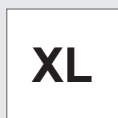

Mattress XL
Materasso XL

FOOT PIEDE



Hemo foot support
Supporto piede Hemo

NEW



Foot pedal control with memories function
Pedaliera con funzione memorie



Wireless foot pedal control with memories function (NO foot pedal with cable NO remote control)
Pedaliera wireless con funzione memorie (NON compatibile con il pedale a filo e con la pulsantiera)



Seat guides couple
Coppia guide seduta



Back guides couple
Coppia guide schiena



Clamps couple (fixed/rotating)
Coppia morsetti (fissi/girevoli)



I.V. Rod
Asta portaflebo



Medical armrest couple (+ back guides and rotating clamps)
Coppia braccioli medicali (+ guide schiena e morsetti girevoli)



Blood sample taking armrest couple (+ seat guides and fixed clamps)
Coppia braccioli da prelievo con snodo (+ guide seduta e morsetti fissi)



Flat armrests couple
Coppia braccioli automatici

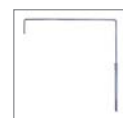

Curtain holder (+ back guides and rotating clamp)
Reggitelo (+ guide schiena e morsetto girevole)



Thigh support couple (+ seat guides and fixed clamps)
Coppia reggicoscie con snodo (+ guide seduta e morsetti fissi)



Roll Holder (66 cm)
Roll Holder (75 cm) for XL mattress
Portarotolo (66 cm)
Portarotolo (75 cm) per materassi XL

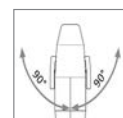

Option 180° rotation
Opzione rotazione 180°



Wheels with brake (ø 50mm)
Ruote con freno (ø 50mm)



Inox tray with support (+ seat guides and fixed clamp)
Vassoio inox completo di telaio (+ guide seduta e morsetto fisso)



Plastic leg protection
Proteggi gambe in plastica



Mattress with customised LOGO
Materasso con LOGO personalizzato

LEMI MATTRESSES

STANDARD

FLAT



THICKNESS
SPESSORE
8cm | 3,1"

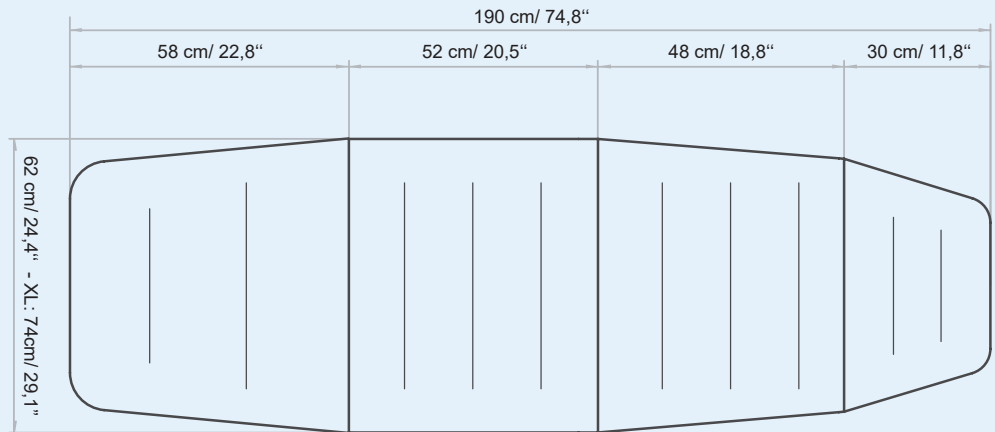

ANATOMIC

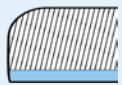

THICKNESS
SPESSORE
12cm | 4,7"

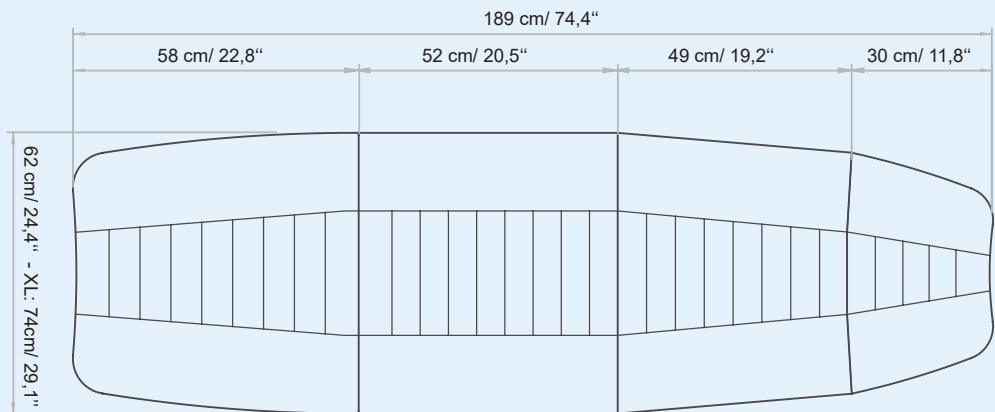

MEMORY

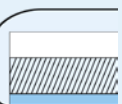

THICKNESS
SPESSORE
15cm | 5,9"

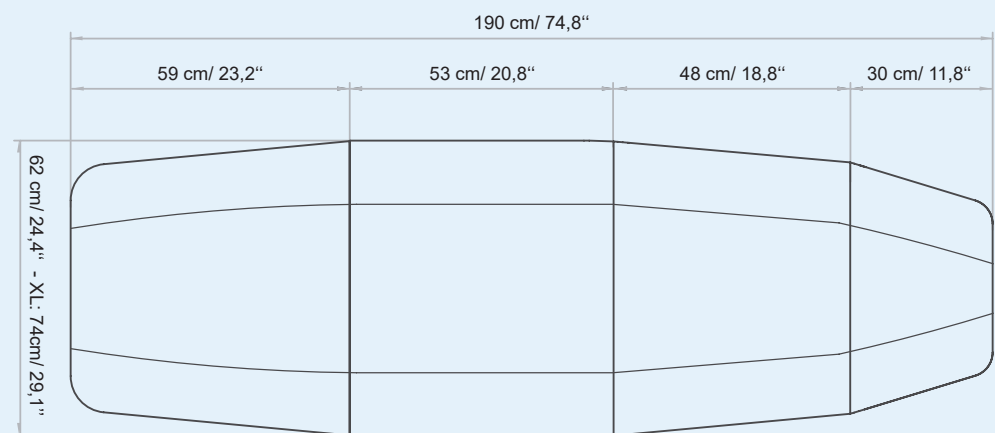

MATERASSI LEMI

BI-ZAK

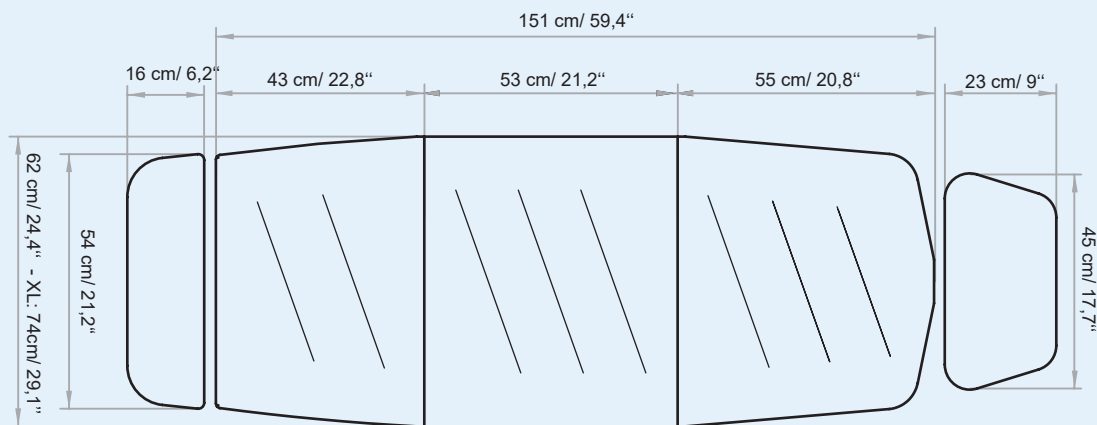

FLAT BI-ZAK



THICKNESS
SPESSORE
8cm | 3,1"

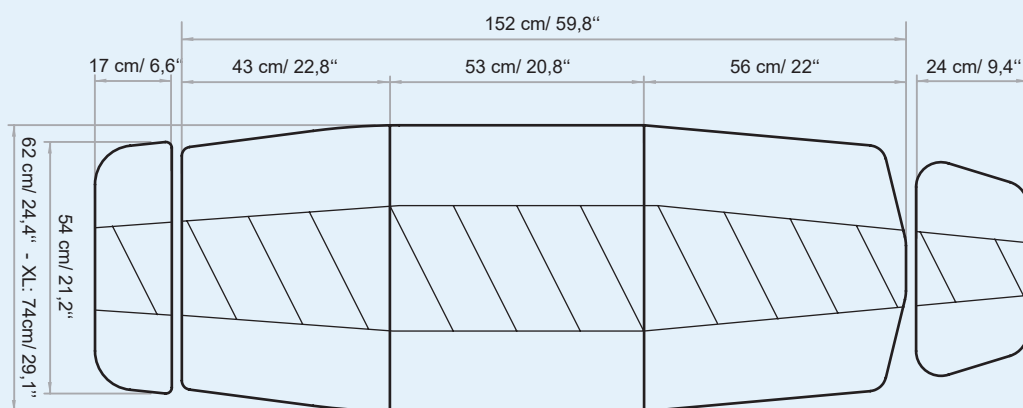

ANATOMIC BI-ZAK

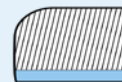

THICKNESS
SPESSORE
12cm | 4,7"

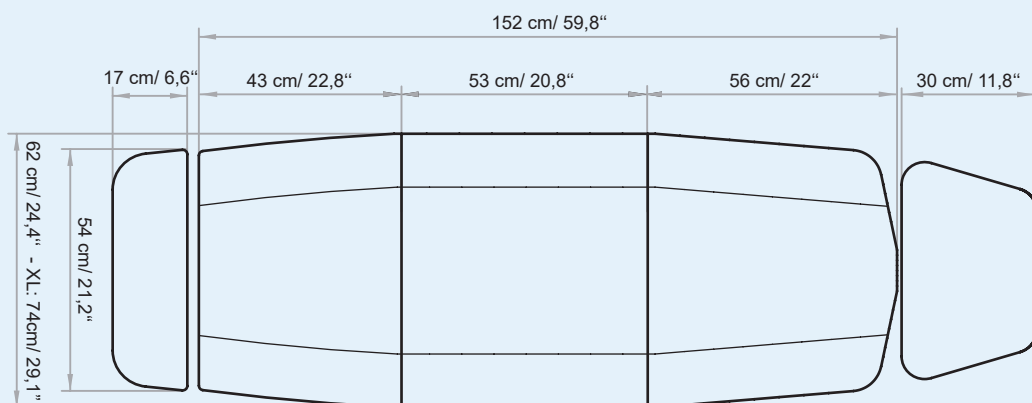

MEMORY BI-ZAK



THICKNESS
SPESSORE
15cm | 5,9"





HEMODIALYSIS BLOOD SAMPLING

EMODIALISI
PRELIEVI



* M: Nefos 6

Standard version / Versione standard

Focus on

- **Standard foot pedal control with 1 MEMORY function** **NEW**
- **AUT function:** automatic return to the original position (chair)
- **SYNCHRO function:** synchronized backrest/legrest movement (ONLY by handset control)
- Fire retardant class 1IM, "Azo" free, antibacterial, antifungal covering
- Entirely enclosed ABS casing
- Fully customizable
- **Standard version includes:** 4 electric motors (height, back, leg, trendelenburg adjustment), foot pedal control and anatomic Bi-Zak mattress (adjustable headrest and footrest), 2 pairs of guides (back and seat) and a roll-holder

- **Pedaliera standard con 1 funzione MEMORIE** **NEW**
- Funzione AUT: ritorno automatico alla posizione base (poltrona)
- Funzione SYNCHRO: movimento schiena/gambe sincronizzato (SOLO con pulsantiera)
- Rivestimento ignifugo classe 1IM, "Azo" free, antibatterico, antimicotico
- Carter in ABS completamente chiuso
- Totalmente personalizzabile
- **La versione standard include:** 4 motori elettrici (regolazione altezza, schienale, gamba, trendelenburg), pedaliera e materasso anatomico Bi-Zak (testa e piedi regolabili), 2 coppie di guide (schiena e seduta) e portarotolo

On demand

Examples of accessories available upon request at page 77

Esempi di accessori disponibili su richiesta a pagina 77



Hemodialysis - blood sampling version
Versione emodialisi - prelievi

* M: Nefos 8019



Gynaecology version
Versione ginecologia

* M: Nefos 5946

COD. 1132

Lemi Med is equipped with high-performance and silent electronics and a practical standard foot pedal control. Bi-Zak mattress with wide customization.

IDEAL FOR: diagnostics, check-up, hemodialysis and blood sampling, gynecological examinations, dermatology and aesthetic surgery.

Lemi Med è dotata di elettronica altamente performante e silenziosa e di una pratica pedaliera standard. Materasso Bi-Zak con ampia possibilità di personalizzazione.

IDEALE PER: diagnostica, check-up, emodialisi e prelievo di sangue, esami ginecologici, dermatologia e chirurgia estetica.

** The images are for illustrative purposes only and may not reflect the actual image of the finishing.*

** Le immagini hanno valore puramente illustrativo e possono non rispecchiare l'immagine reale della finitura.*

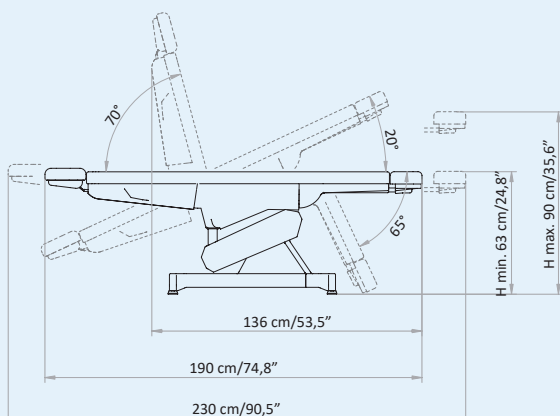

Packaging details

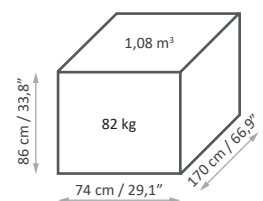

MAXIMUM CAPACITY
PORTATA MASSIMA

200 kg

HEMODIALYSIS BLOOD SAMPLING EMODIALISI PRELIEVI

x2



Blood sample taking armrests (couple)

Braccioli da prelievo (coppia)

68



I.V. Rod + rotating clamp (x1)
Asta portaflebo + Morsetto girevole (x1)

x1



x1



Fixed clamp (couple)

Morsetti fissi (coppia)

x2



x1



NEW

Hemo foot support
Supporto piede Hemo

GYNAECOLOGY GINECOLOGIA LEMI MED



*Thigh support
(couple)*

*Reggicosce
(coppia)*

69



*Fixed clamp
(couple)*

*Morsetti fissi
(coppia)*



x2

STANDARD CONTROL

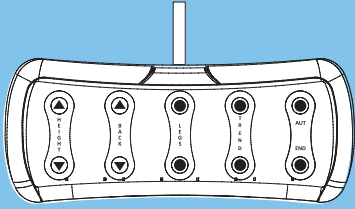

4 ELECTRIC MOTORS



M1 - MEMORY FUNCTION



AUT FUNCTION



SYNCHRO FUNCTION



Removable Zak headrest
Testa Zak estraibile

63-90 cm
(24,8"-35,6")

Electric height
Altezza elettrica



20°



Electric Trendelenburg
Trendelenburg elettrico

COMANDO STANDARD

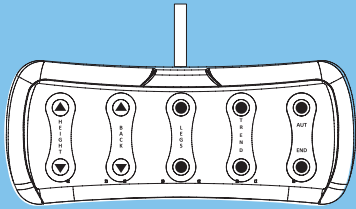

4 MOTORI
ELETTRICI



M1 - FUNZIONE
MEMORIE



FUNZIONE
AUT



FUNZIONE
SYNCHRO

Electric backrest
Schiena elettrica



70°

Electric legrest
Gamba elettrica



65°

Hemodialysis / blood sampling version
Versione emodialisi / prelievi

Removable Hemo foot support
Supporto piede Hemo estraibile



72

* M: Nefos 8019

Standard version / Versione standard

Focus on

- *Standard handset control*
- **NEW** *SYNCHRO function: synchronized backrest/legrest movement*
- *Fire retardant class 1IM, "Azo" free, antibacterial, antifungal covering*
- *Move base with retractable wheels*
- *Standard version includes: 3 electric motors (legs, backrest, trendelenburg adjustment), handset control and "Easy-to-clean" anatomic mattress without stitching, adjustable legrest, seat guides, blood sample taking armrests, fixed clamps and roll holder*

- *Pulsantiera standard*
- **NEW** *Funzione SYNCHRO: movimento schiena/gambe sincronizzato*
- *Rivestimento ignifugo classe 1IM, "Azo" free, antibatterico, antimicotico*
- *Base move con ruote a scomparsa*
- *La versione standard include: 3 motori elettrici (regolazione gambe, schiena e trendelenburg), pulsantiera e materasso anatomico senza cuciture "easy-to-clean", gambe regolabili, guide seduta, coppia di braccioli da prelievo, morsetti fissi e portarotolo*

On demand

Examples of accessories available upon request at page 77

Esempi di accessori disponibili su richiesta a pagina 77

HE-MOVE

UPGRADE

COD. 1182

He-Move is equipped with high-performance and silent electronics and a practical standard handset control. Easily movable, thanks to the retractable wheels, guarantees maximum ease of cleaning for aseptic clinical environments.

IDEAL FOR: blood sampling and hemodialysis.

He-Move è dotata di elettronica altamente performante e silenziosa e di una pratica pulsantiera standard. Facilmente spostabile grazie alle comode ruote a scomparsa, facilita l'igienizzazione degli ambienti asettici, come quelli clinici.

IDEALE PER: prelievi ed emodialisi.



** The images are for illustrative purposes only and may not reflect the actual image of the finishing.*

** Le immagini hanno valore puramente illustrativo e possono non rispecchiare l'immagine reale della finitura.*

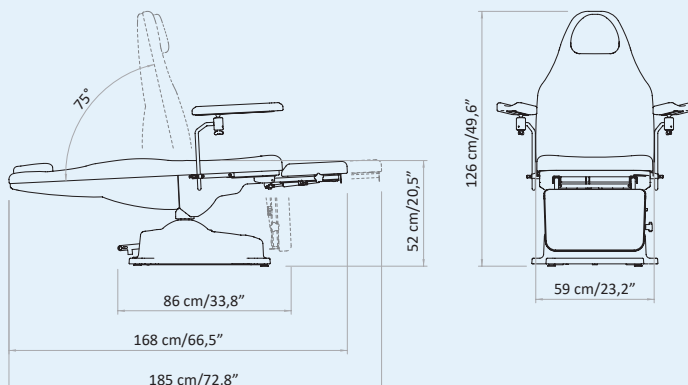

Packaging details

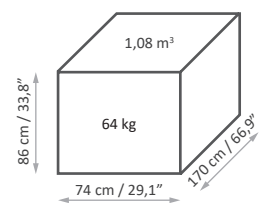

MAXIMUM CAPACITY
PORTATA MASSIMA

200 kg



STANDARD CONTROL

3M

3 ELECTRIC
MOTORS



ELECTRIC LEG
ADJUSTMENT



SYNCHRO
FUNCTION



Anatomic mattress without stitching for maximum comfort
Materasso anatomico senza cuciture per massimo comfort



Electric Trendelenburg
Trendelenburg elettrico



Manually adjustable footrest
Appoggia piedi regolabile manualmente



COMANDO STANDARD

3M

3 MOTORI
ELETTRICI



REGOLAZIONE
ELETTRICA GAMB
A



FUNZIONE
SYNCHRO



Electric backrest
Schiena elettrica



Adjustable headrest
Testa regolabile



Electric legrest
Gambe elettriche



LEMI STANDARD

Choose the medical chair with STANDARD CONFIGURATION by LEMI
Scegli la poltrona medica con la CONFIGURAZIONE STANDARD by LEMI

LEMI MED



1
ANATOMIC BI-ZAK
MATTRESS

4
BACK GUIDES
COUPLE

3
SEAT GUIDES
COUPLE

2
FOOT PEDAL
CONTROL

ANATOMIC BI-ZAK MATTRESS MATERASSO ANATOMICO BI-ZAK

Materasso standard Bi-Zak anatomico
Standard Bi-Zak anatomic mattress

FOOT PEDAL CONTROL PEDALIERA

Practical foot pedal control for chair adjustment
Pratica pedaliera per regolazione poltrona

SEAT GUIDES COUPLE COPPIA GUIDE SEDUTA

Seat guides for accessories
Guide seduta per accessori

BACK GUIDES COUPLE COPPIA GUIDE SCHIENA

Back guides for accessories
Guide schiena per accessori

ACCESSORIES UPON REQUEST ACCESSORI SU RICHIESTA

Customize the medical chair with the ACCESSORIES available on request.
Personalizza la poltrona medica con gli ACCESSORI disponibili su richiesta.

HEADS TESTE



*Small Zak headrest
(only for Bi-Zak version)*
Testa Zak piccola
(solo per versione Bi-Zak)



*Strip headrest
(only for Bi-Zak version)*
Testa strip
(solo per versione Bi-Zak)

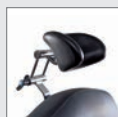

*Anto headrest for hair transplant
(only for Bi-Zak version)*
Testa Anto per trapianto capelli
(solo per versione Bi-Zak)



*Medical armrest couple
(+ back guides and rotating clamps)*
Coppia braccioli medicali
(+ guide schiena e morsetti girevoli)



*Blood sample taking armrest couple
(+ seat guides and fixed clamps)*
Coppia braccioli da prelievo
(+ guide seduta e morsetti fissi)

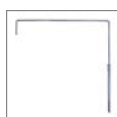

*Curtain holder
(+ back guides and rotating clamps)*
Reggitele
(+ guide schiena e morsetti girevoli)



*Thigh support couple
(+ seat guides and fixed clamps)*
Coppia reggicosce con snodo
(+ guide seduta e morsetti fissi)



*Inox tray with support
(+ seat guides and fixed clamps)*
Vassoio inox completo di telaio
(+ guide seduta e morsetti fissi)



Wheels with brake (ø 50mm)
Ruote con freno (ø 50mm)

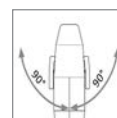

Option 180° rotation
Opzione rotazione 180°

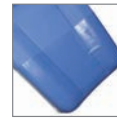

Plastic leg protection
Proteggi gambe in plastica



*Mattress with
customised LOGO*
Materasso con LOGO
personalizzato

MATTRESSES MATERASSI



Mattress without stitching
Materasso senza cuciture

FOOT PIEDE



Hemo foot support
Supporto piede Hemo



*Clamps couple
(fixed/rotating)*
Coppia morsetti
(fissi/girevoli)

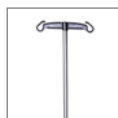

I.V. Rod
Asta portaflebo



*Handset control with
memories function*
Pulsantiera con funzione
memorie



*Wireless foot pedal control with
memories (NO foot pedal with
cable NO remote control)*
Pedaliera wireless con memorie
(NON compatibile con il pedale
a filo e con la pulsantiera)

NEW

LEMI MATTRESSES

The MATTRESSES of the LEMI MEDICAL line are made with the best quality materials to ensure maximum comfort for both the patient and the doctor.

LEMI MED - HEMO



THICKNESS
SPESSORE
12cm | 4,7"

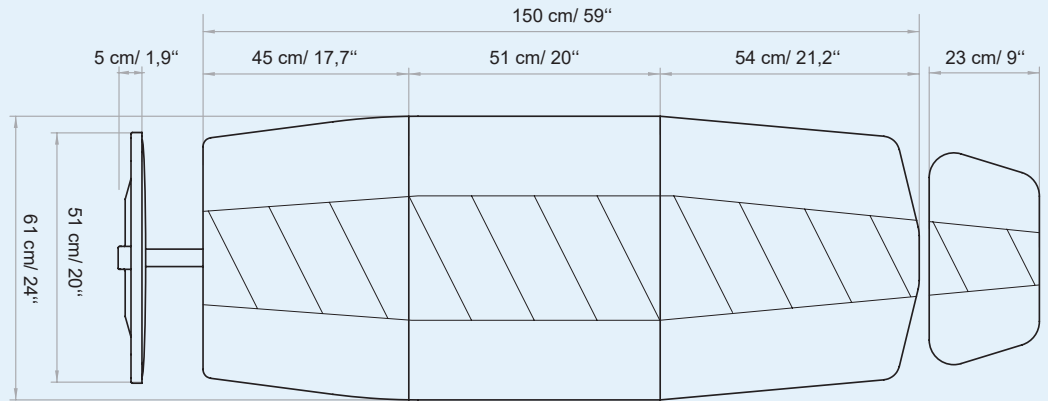

HE-MOVE



THICKNESS
SPESSORE
9cm | 3,5"

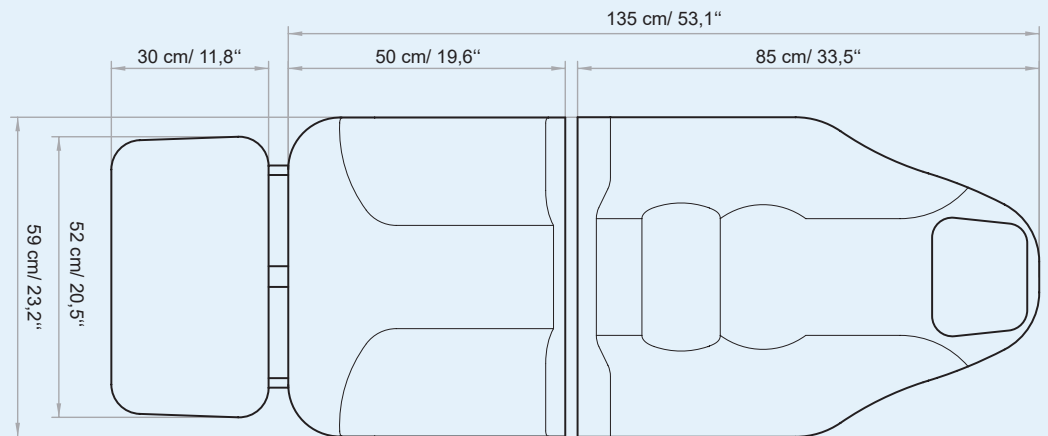

LEMI MED - GYNO



THICKNESS
SPESSORE
12cm | 4,7"

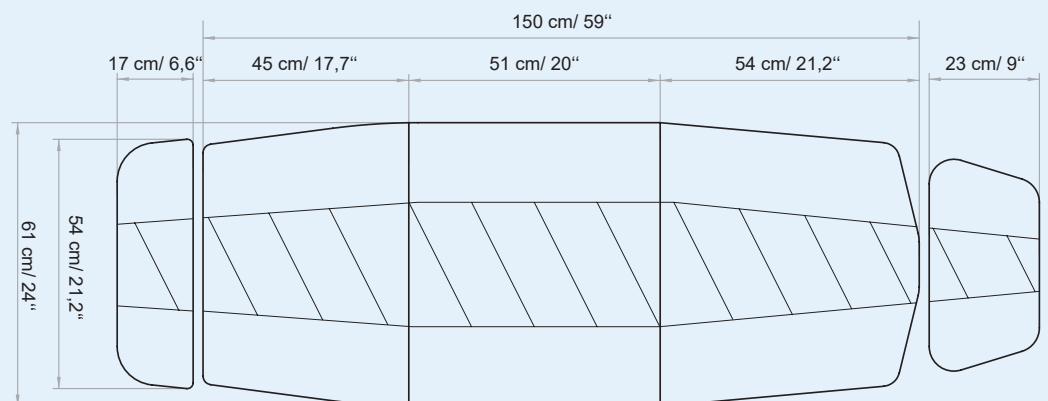

MATERASSI LEMI

I MATERASSI della linea MEDICALE LEMI sono realizzati con materiali della migliore qualità per garantire il massimo comfort sia per il paziente che per il medico.

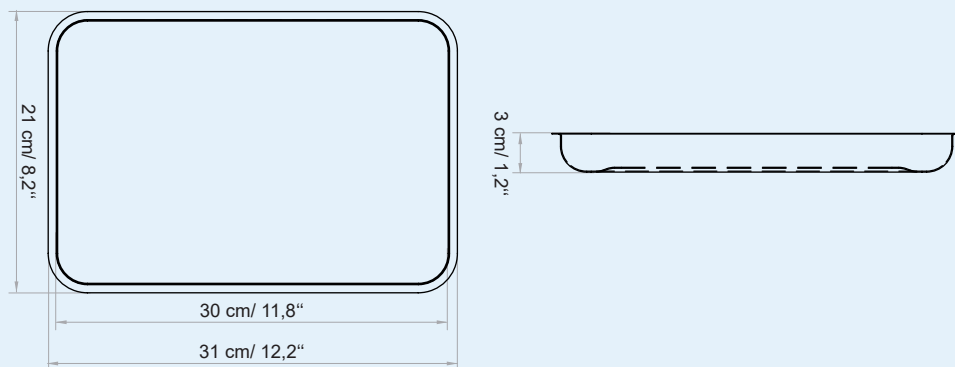

INOX TRAY
VASSOIO INOX

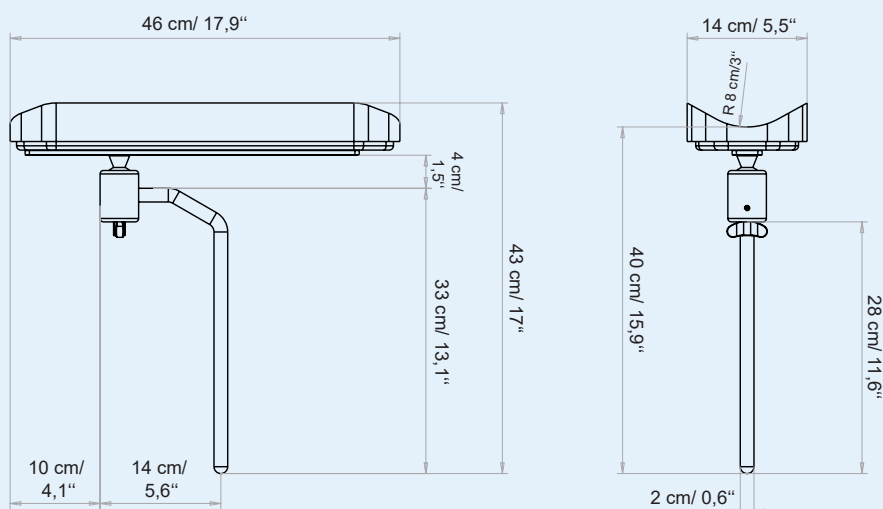

MEDICAL ARMRESTS

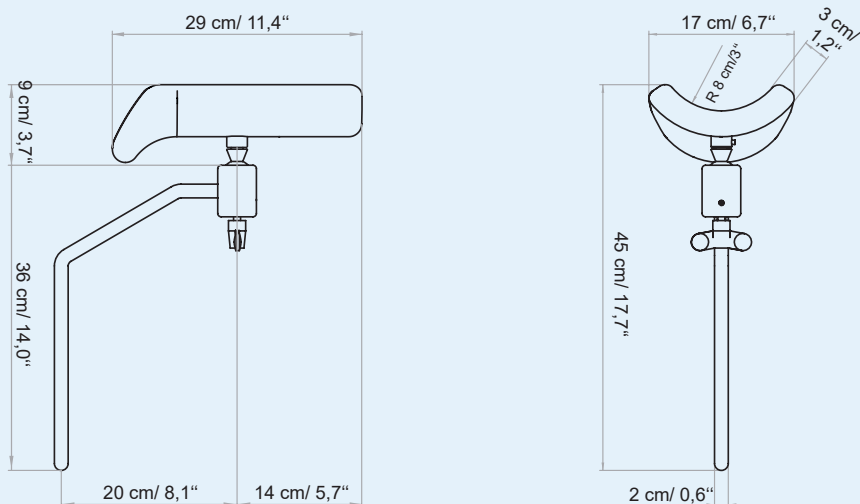

THIGH SUPPORT







CHEMOTHERAPY ONCOLOGY

CHEMIOTERAPIA
ONCOLOGIA



82

* M: Nefos 5946

Seat guides version / Versione con guide seduta

Focus on

- Standard handset control with 1 MEMORY function **NEW**
- AUT function: automatic return to the original position (chair)
- SYNCHRO function: synchronized backrest/legrest movement
- Move base with retractable wheels
- Fire retardant class 1IM, "Azo" free, antibacterial, antifungal covering
- Standard version includes: 3 electric motors (backrest, legrest, trendelenburg adjustment), handset control and extra-comfort Bi-Zak mattress without stitching, back guides, medical armrests, rotating clamps

- Pulsantiera standard con 1 funzione MEMORIE **NEW**
- Funzione AUT: ritorno automatico alla posizione base (poltrona)
- Funzione SYNCHRO: movimento schiena/gambe sincronizzato
- Base Move con ruote a scomparsa
- Rivestimento ignifugo classe 1IM, "Azo" free, antibatterico, antimicotico
- La versione standard include: 3 motori elettrici (regolazione schiena, gambe e trendelenburg), pulsantiera e materasso extra comfort Bi-Zak senza cuciture, guide schiena, coppia braccioli medicali, morsetti girevoli

On demand

Examples of accessories available upon request at page 87

Esempi di accessori disponibili su richiesta a pagina 87



COD. 1181

Ke-Treat is equipped with high-performance and silent electronics and a practical standard handset control. Designed for chemotherapy and oncology sessions involving long and delicate procedures. Easily movable, thanks to the retractable wheels, guarantees maximum ease of cleaning for aseptic clinical environments.

IDEAL FOR: chemotherapy and oncology.

Ke-Treat è dotata di elettronica altamente performante e silenziosa e di una pratica pulsantiera standard. Studiata per sedute di chemioterapia e oncologia che richiedono procedure lunghe e delicate. Facilmente spostabile grazie alle comode ruote a scomparsa, facilita l'igienizzazione degli ambienti asettici, come quelli clinici.

IDEALE PER: chemioterapia e oncologia.

** The images are for illustrative purposes only and may not reflect the actual image of the finishing.*

** Le immagini hanno valore puramente illustrativo e possono non rispecchiare l'immagine reale della finitura.*

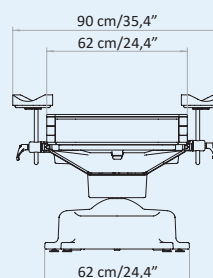
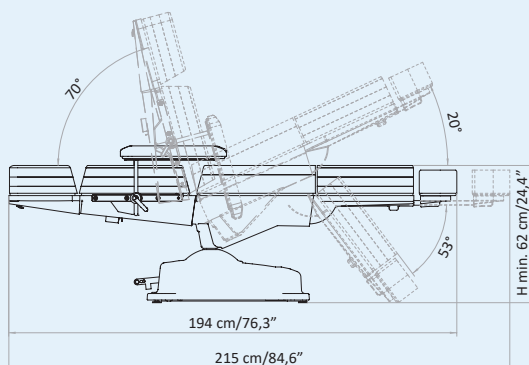

Packaging details

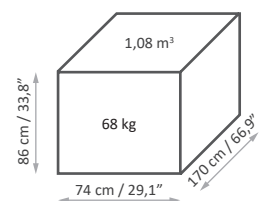

MAXIMUM CAPACITY
PORTATA MASSIMA

200 kg



STANDARD CONTROL



3 ELECTRIC MOTORS



M1 - MEMORY FUNCTION



AUT FUNCTION



SYNCHRO FUNCTION



Extremely comfortable 5 section mattress without stitching, ideal for long therapies

Materasso senza cuciture in 5 sezioni estremamente confortevole, ideale per trattamenti di lunga durata

Synchronized backrest/legrest movement
Movimento sincronizzato schiena/gambe



20°



Electric Trendelenburg
Trendelenburg elettrico

Seat guides version
Versione con guide seduta



COMANDO STANDARD



3 MOTORI
ELETTRICI



M1 - FUNZIONE
MEMORIE



FUNZIONE
AUT



FUNZIONE
SYNCHRO



70°

Electric backrest
Schiena elettrica



Adjustable headrest
Testa regolabile



53°

Electric legrest
Gambe elettriche

LEMI STANDARD

Choose the medical chair with STANDARD CONFIGURATION by LEMI
Scegli la poltrona medica con la CONFIGURAZIONE STANDARD by LEMI

KE-TREAT



1 MEMORY FOAM MATTRESS MATERASSO MEMORY FOAM

Materasso standard Memory Foam
Standard Memory Foam mattress

2 RETRACTABLE WHEELS RUOTE A SCOMPARSA

Practical wheels for chair adjustment
Pratiche ruote per movimentazione poltrona

3 MEDICAL ARMREST COUPLE COPPIA BRACCIOLI MEDICALI

Practical medical armrests
Pratici braccioli medicali

4 BACK GUIDES COUPLE COPPIA GUIDE SCHIENA

Back guides for accessories
Guide schiena per accessori

ACCESSORIES UPON REQUEST ACCESSORI SU RICHIESTA

Customize the medical chair with the ACCESSORIES available on request.
Personalizza la poltrona medica con gli ACCESSORI disponibili su richiesta.

I.V. ROD ASTA PORTAFLEBO



I.V. Rod
Asta portaflebo



Support for I.V. Rod
Supporto per Asta portaflebo



*Clamps couple
(fixed/rotating)*
Coppia morsetti
(fissi/girevoli)

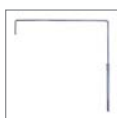

*Curtain holder
(+ back guides and rotating clamps)*
Reggitelo
(+ guide schiena e morsetti girevoli)



*Inox tray with support
(+ seat guides and fixed clamps)*
Vassoio inox con supporto
(+ guide seduta e morsetti fissi)



Roll Holder (66 cm)
Portarotolo (66 cm)



Seat guide couple
Coppia guide seduta



Plastic leg protection
Proteggi gambe in plastica



Mattress with customised LOGO
Materasso con LOGO personalizzato

LEMI MATTRESSES

The MATTRESSES of the LEMI MEDICAL line are made with the best quality materials to ensure maximum comfort for both the patient and the doctor.



KE-TREAT

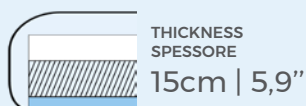
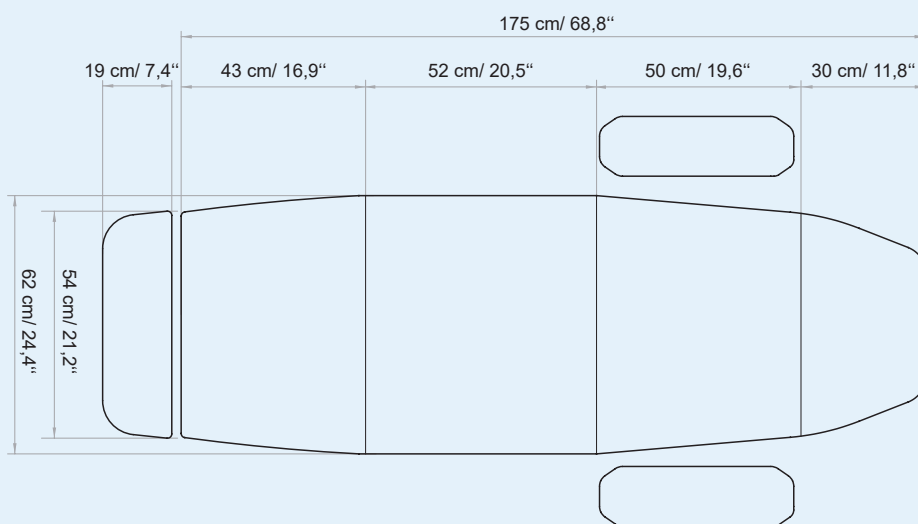

MEMORY FOAM MATTRESS

Super Soft Mattress in Memory Foam **Thickness: 15 cm / 5,9"**

The Memory Foam mattress allows an optimal comfort for the patient even for long-lasting treatments. Furthermore, with the handset control supplied, the patient can independently adjust the chair to find the most comfortable position.

Materasso Super Soft in Memory Foam **Spessore: 15 cm**

Il materasso in Memory Foam permette un comfort ottimale del paziente anche per trattamenti di lunga durata. Inoltre con la pulsantiera in dotazione il paziente può regolare in autonomia la poltrona trovando la posizione più comoda.

MATERASSI LEMI

I MATERASSI della linea MEDICALE LEMI sono realizzati con materiali della migliore qualità per garantire il massimo comfort sia per il paziente che per il medico.

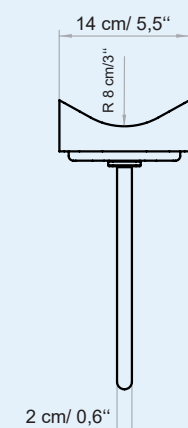
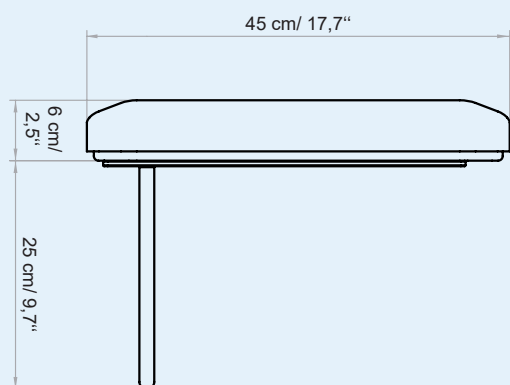

MEDICAL ARMRESTS



Adjustable Medical armrest
Braccioli medicali regolabili



Adjustable and removable footrest
Piede regolabile ed estraibile





ENT - OPHTHALMOLOGY
DENTISTRY

ORL - OPHTHALMOLOGIA
ODONTOLOGIA



92

* M: Nefos 5946

Version with seat guides / Versione con guide seduta

Stool 070A

Focus on

- **Standard foot pedal control with 1 MEMORY function** **NEW**
- **AUT function:** automatic return to the original position (chair)
- **SYNCHRO function:** synchronized backrest/legrest movement (ONLY by handset control)
- **Fire retardant class 1IM, "Azo" free, antibacterial, antifungal covering**
- **Entirely enclosed ABS casing**
- **Standard version includes: 4 electric motors (height, back, leg, trendelenburg adjustment), foot pedal control, "Easy-to-clean" anatomic mattress without stitches, head support, 180° rotation, predisposition for back guides**

- **Pedaliera standard con 1 funzione MEMORIE** **NEW**
- **Funzione AUT:** ritorno automatico alla posizione base (poltrona)
- **Funzione SYNCHRO:** movimento schiena/gambe sincronizzato (SOLO con pulsantiera)
- **Rivestimento ignifugo classe 1IM, "Azo" free, antibatterico, antimicotico**
- **Carter in ABS completamente chiuso**
- **La versione standard include: 4 motori elettrici (regolazione altezza, schienale, gamba, trendelenburg), pedaliera, materasso anatomico senza cuciture "easy-to-clean", appoggiatesta, rotazione 180°, predisposizione per guide schiena**

On demand

Examples of accessories available upon request at page 117

Esempi di accessori disponibili su richiesta a pagina 117

DREAMED UPGRADE

COD. 1175

Dreamed is equipped with high-performance and silent electronics and a practical standard foot pedal control. The shape of the backrest is designed to approach the patient face and the base size is suitable also for small rooms.

IDEAL FOR: diagnostics, ENT, dental and ophthalmic examinations.

Dreamed è dotata di elettronica altamente performante e silenziosa e di una pratica pedaliera standard. La forma dello schienale è studiata per avvicinarsi al volto del paziente e l'ingombro della base è idoneo anche per le stanze piccole.

IDEALE PER: visite diagnostiche, ORL, dentali e oftalmologiche.



** The images are for illustrative purposes only and may not reflect the actual image of the finishing.*

** Le immagini hanno valore puramente illustrativo e possono non rispecchiare l'immagine reale della finitura.*

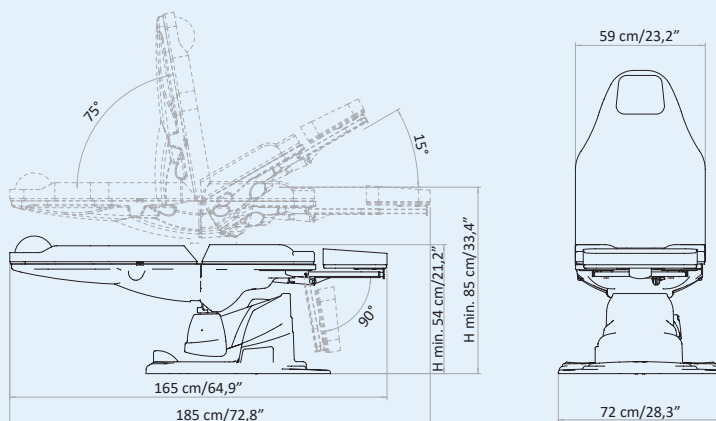

Packaging details

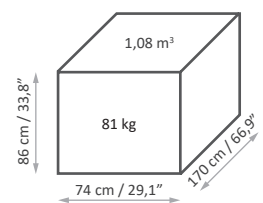

MAXIMUM CAPACITY
PORTATA MASSIMA

200 kg

STANDARD CONTROL

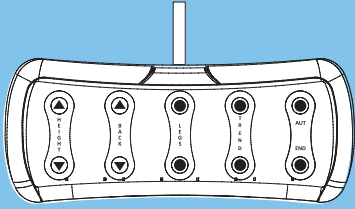

4 ELECTRIC MOTORS



M1 - MEMORY FUNCTION



AUT FUNCTION



SYNCHRO FUNCTION



Head support - Manually adjustable cushion
Poggiatesta - Cuscino regolabile manualmente

54-85 cm
(21,2" - 33,4")



Electric height
Altezza elettrica



15°

Electric Trendelenburg
Trendelenburg elettrico



180°

90° rotation on both sides
Rotazione 90° da entrambi i lati

Version with seat guides
Versione con guide seduta

COMANDO STANDARD

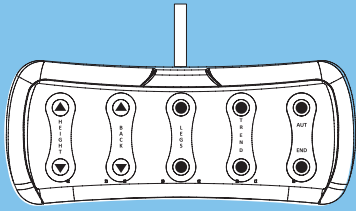

4 MOTORI
ELETTRICI



M1 - FUNZIONE
MEMORIE



FUNZIONE
AUT



FUNZIONE
SYNCHRO



Synchronized backrest/legrest movement
Movimentazione sincronizzata schiena/gambe



DREAMED MOVE



96

* M: Nefos 5946

Version with seat guides / Versione con guide seduta

Focus on

- Standard foot pedal control with 1 MEMORY function **NEW**

- AUT function: automatic return to the original position (chair)
- SYNCHRO function: synchronized backrest/legrest movement (ONLY by handset control)
- Fire retardant class 1IM, "Azo" free, antibacterial, antifungal covering

- Standard version includes: 4 electric motors (height, back, leg, trendelenburg adjustment), foot pedal control, "Easy-to-clean" anatomic mattress without stitches, head support, MOVE base with integrated wheels, predisposition for back guides

- Pedaliera standard con 1 funzione MEMORIE **NEW**

- Funzione AUT: ritorno automatico alla posizione base (poltrona)
- Funzione SYNCHRO: movimento schiena/gambe sincronizzato (SOLO con pulsantiera)
- Rivestimento ignifugo classe 1IM, "Azo" free, antibatterico, antimicotico

- La versione standard include: 4 motori elettrici (regolazione altezza, schienale, gamba, trendelenburg), pedaliera, materasso anatomico senza cuciture "easy-to-clean", appoggiatesta, base MOVE con ruote integrate, predisposizione per guide schiena

On demand

Examples of accessories available upon request at page 117

Esempi di accessori disponibili su richiesta a pagina 117



Move base / Base move



COD. 1209

Dreamed Move is equipped with high-performance and silent electronics and a practical standard foot pedal control. The shape of the backrest is designed to approach the patient face. The move base helps with cleaning and disinfection of medical environments and the base size is suitable also for small rooms.

IDEAL FOR: diagnostics, ENT, dental and ophthalmic examinations.

Dreamed Move è dotata di elettronica altamente performante e silenziosa e di una pratica pedaliera standard. La forma dello schienale è studiata per avvicinarsi al volto del paziente. La base MOVE facilita la pulizia e disinfezione dell'ambiente medico e l'ingombro della base è idoneo anche per le stanze piccole.

IDEALE PER: visite diagnostiche, ORL, dentali e oftalmologiche.

** The images are for illustrative purposes only and may not reflect the actual image of the finishing.*

** Le immagini hanno valore puramente illustrativo e possono non rispecchiare l'immagine reale della finitura.*

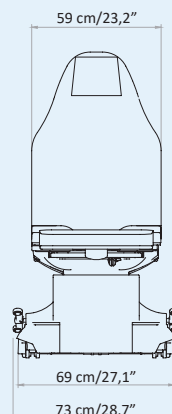
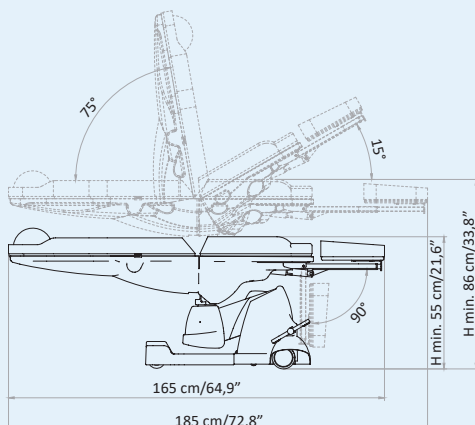

Packaging details

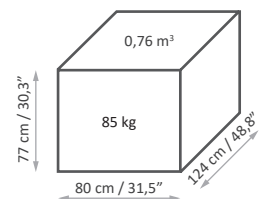

MAXIMUM CAPACITY
PORTATA MASSIMA

200 kg

STANDARD CONTROL

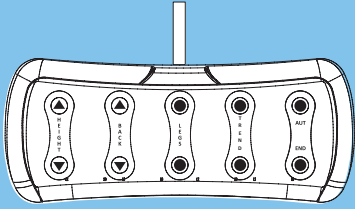

4 ELECTRIC MOTORS



M1 - MEMORY FUNCTION



AUT FUNCTION



SYNCHRO FUNCTION



Head support
Manually adjustable cushion

Poggiatesta
Cuscino regolabile manualmente

55-86 cm
(21,6"-33,8")

Electric height
Altezza elettrica



15°



Electric Trendelenburg
Trendelenburg elettrico

Version with seat guides
Versione con guide seduta

COMANDO STANDARD

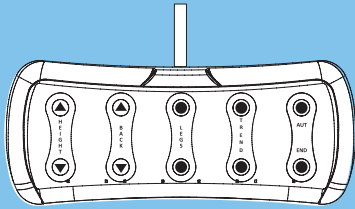

4 MOTORI
ELETTRICI



M1 - FUNZIONE
MEMORIE



FUNZIONE
AUT



FUNZIONE
SYNCHRO



MOVE base with integrated wheels
Base MOVE con ruote integrate

Front wheels: Ø100 cm with brake
Rear wheels: Ø80 cm without brake
Ruote anteriori: Ø100 cm con freno
Ruote posteriori: Ø80 cm senza freno



75°

Electric backrest
Schiena elettrica



Electric legrest
Gambe elettriche

90°



90° leg inclination
Inclinazione gambe a 90°

DREAMED ZAK



100

* M: Nefos 8009

Version with medical armrests and seat guides / Versione con braccioli medicali e guide seduta

Focus on

▪ Standard foot pedal control with 1 MEMORY function **NEW**

- AUT function: automatic return to the original position (chair)
- SYNCHRO function: synchronized backrest/legrest movement (ONLY by handset control)
- Fire retardant class 1IM, "Azo" free, antibacterial, antifungal covering
- Entirely enclosed ABS casing

▪ Standard version includes: 4 electric motors (height, back, leg, trendelenburg adjustment), foot pedal control, "Easy-to-clean" seamless anatomic mattress with Zak headrest, 180° rotation, back guides

▪ Pedaliera standard con 1 funzione MEMORIE **NEW**

- Funzione AUT: ritorno automatico alla posizione base (poltrona)
- Funzione SYNCHRO: movimento schiena/gambe sincronizzato (SOLO con pulsantiera)
- Rivestimento ignifugo classe 1IM, "Azo" free, antibatterico, antimicotico
- Carter in ABS completamente chiuso

▪ La versione standard include: 4 motori elettrici (regolazione altezza, schienale, gamba, trendelenburg), pedaliera, materasso anatomico senza cuciture "easy-to-clean" con testa Zak, rotazione 180°, guide schiena

On demand

Examples of accessories available upon request at page 117

Esempi di accessori disponibili su richiesta a pagina 117

DREAMED ZAK

UPGRADE



COD. 1208

Dreamed Zak is equipped with high-performance and silent electronics and a practical standard foot pedal control. The shape of the backrest is designed to approach the patient face and the base size is suitable also for small rooms.

IDEAL FOR: diagnostics, ENT, dental and ophthalmic examinations.

Dreamed Zak è dotata di elettronica altamente performante e silenziosa e di una pratica pedaliera standard. La forma dello schienale è studiata per avvicinarsi al volto del paziente e l'ingombro della base è idoneo anche per le stanze piccole.

IDEALE PER: visite diagnostiche, ORL, dentali e oftalmologiche.

** The images are for illustrative purposes only and may not reflect the actual image of the finishing.*

** Le immagini hanno valore puramente illustrativo e possono non rispecchiare l'immagine reale della finitura.*

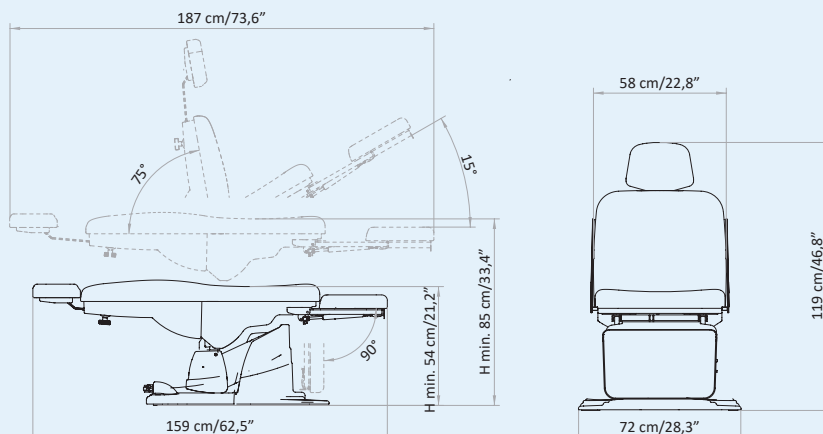

Packaging details

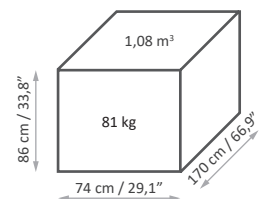

MAXIMUM CAPACITY
PORTATA MASSIMA

200 kg

STANDARD CONTROL

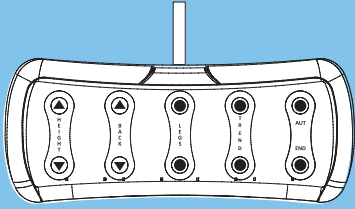

4 ELECTRIC MOTORS



M1 - MEMORY FUNCTION



AUT FUNCTION



SYNCHRO FUNCTION



Zak headrest
Testa zak

54-85 cm
(21,2"-33,4")

Electric height
Altezza elettrica



Electric Trendelenburg
Trendelenburg elettrico



15°

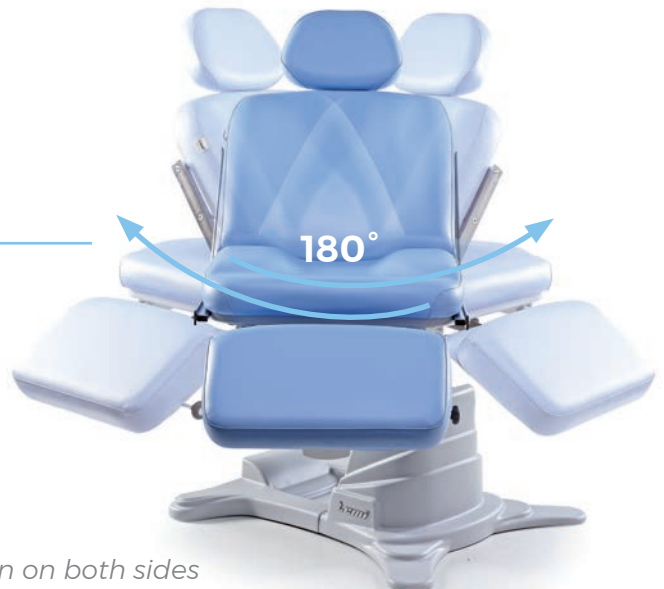

180°

Version with seat guides
Versione con guide seduta

90° rotation on both sides
Rotazione 90° da entrambi i lati

COMANDO STANDARD

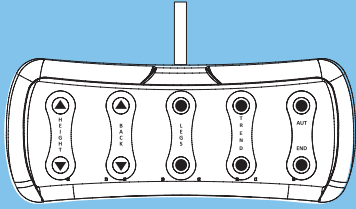

4 MOTORI
ELETTRICI



M1 - FUNZIONE
MEMORIE



FUNZIONE
AUT



FUNZIONE
SYNCHRO

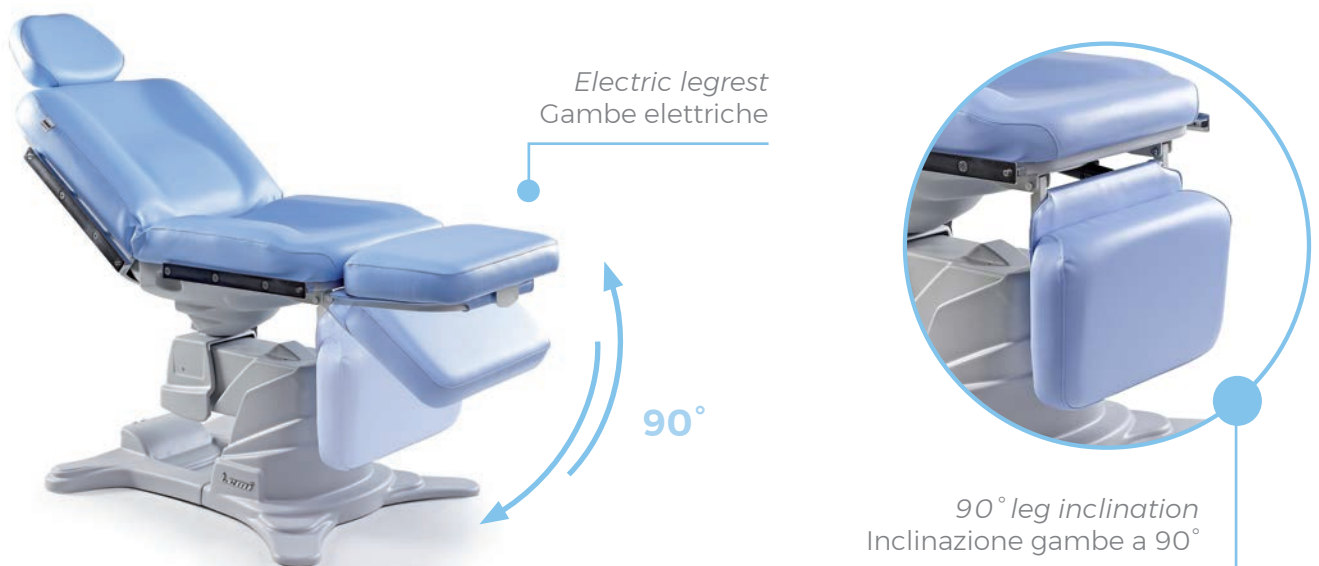

DREAMED ZAK MOVE



104

* M: Nefos 8009

Version with medical armrests and seat guides / Versione con braccioli medicali e guide seduta

Focus on

▪ **Standard foot pedal control with 1 MEMORY function** **NEW**

- AUT function: automatic return to the original position (chair)
- SYNCHRO function: synchronized backrest/legrest movement (ONLY by handset control)
- Fire retardant class 1IM, "Azo" free, antibacterial, antifungal covering

▪ **Standard version includes: 4 electric motors (height, back, leg, trendelenburg adjustment), foot pedal control, "Easy-to-clean" seamless anatomic mattress with Zak headrest, MOVE base with integrated wheels, back guides**

▪ **Pedaliere standard con 1 funzione MEMORIE** **NEW**

- Funzione AUT: ritorno automatico alla posizione base (poltrona)
- Funzione SYNCHRO: movimento schiena/gambe sincronizzato (SOLO con pulsantiera)
- Rivestimento ignifugo classe 1IM, "Azo" free, antibatterico, antimicotico

▪ **La versione standard include: 4 motori elettrici (regolazione altezza, schienale, gamba, trendelenburg), pedaliere, materasso anatomico senza cuciture "easy-to-clean" con testa Zak, base MOVE con ruote integrate, guide schiena**

On demand

Examples of accessories available upon request at page 117

Esempi di accessori disponibili su richiesta a pagina 117

DREAMED ZAK MOVE

UPGRADE



Move base / Base move



COD. 1157

Dreamed Zak Move is equipped with high-performance and silent electronics and a practical standard foot pedal control. The shape of the backrest is designed to approach the patient face. The move base helps with cleaning and disinfection of medical environments and the base size is suitable also for small rooms.

IDEAL FOR: diagnostics, ENT, dental and ophthalmic examinations.

Dreamed Zak Move è dotata di elettronica altamente performante e silenziosa e di una pratica pedaliera standard. La forma dello schienale è studiata per avvicinarsi al volto del paziente. La base MOVE facilita la pulizia e disinfezione dell'ambiente medico e l'ingombro della base è idoneo anche per le stanze piccole.

IDEALE PER: visite diagnostiche, ORL, dentali e oftalmologiche.

** The images are for illustrative purposes only and may not reflect the actual image of the finishing.*

** Le immagini hanno valore puramente illustrativo e possono non rispecchiare l'immagine reale della finitura.*

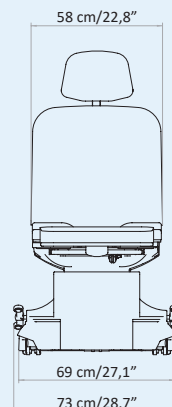
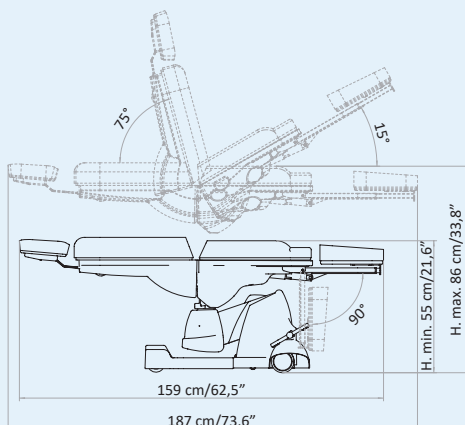

Packaging details

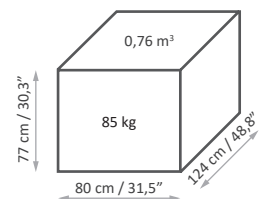

MAXIMUM CAPACITY
PORTATA MASSIMA

200 kg

STANDARD CONTROL

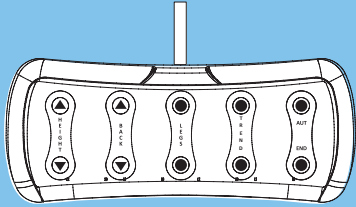

4 ELECTRIC MOTORS



M1 - MEMORY FUNCTION



AUT FUNCTION



SYNCHRO FUNCTION



Easy-to-clean anatomic mattress without stitching
Materasso anatomico senza cuciture per una facile igienizzazione

55-86 cm
(21,6"-33,8")



Electric height
Altezza elettrica



15°



Electric Trendelenburg
Trendelenburg elettrico

Version with seat guides
Versione con guide seduta

COMANDO STANDARD

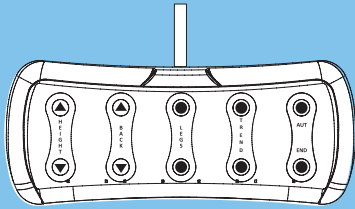

4 MOTORI
ELETTRICI



M1 - FUNZIONE
MEMORIE



FUNZIONE
AUT



FUNZIONE
SYNCHRO



MOVE base with integrated wheels
Base MOVE con ruote integrate

Front wheels: Ø100 cm with brake
Rear wheels: Ø80 cm without brake
Ruote anteriori: Ø100 cm con freno
Ruote posteriori: Ø80 cm senza freno



75°

Electric backrest
Schiena elettrica



Electric legrest
Gambe elettriche

90°



90° leg inclination
Inclinazione gambe a 90°



108

* M: Nefos 1868

Standard version / Versione standard

Focus on

- **Standard foot pedal control with 1 MEMORY function** **NEW**
- **AUT function:** automatic return to the original position (chair)
- **SYNCHRO function:** synchronized backrest/legrest movement (ONLY by handset control)
- Fire retardant class 1IM, "Azo" free, antibacterial, antifungal covering
- Entirely enclosed ABS casing
- **Standard version includes: 4 electric motors (height, back, leg, trendelenburg adjustment), foot pedal control, "Easy-to-clean" seamless anatomic mattress with Zak headrest, 180° rotation, back guides**

- **Pedaliera standard con 1 funzione MEMORIE** **NEW**
- Funzione AUT: ritorno automatico alla posizione base (poltrona)
- Funzione SYNCHRO: movimento schiena/gambe sincronizzato (SOLO con pulsantiera)
- Rivestimento ignifugo classe 1IM, "Azo" free, antibatterico, antimicotico
- Carter in ABS completamente chiuso
- **La versione standard include: 4 motori elettrici (regolazione altezza, schienale, gamba, trendelenburg), pedaliera, materasso anatomico senza cuciture "easy-to-clean" con testa Zak, rotazione 180°, guide schiena**

On demand

Examples of accessories available upon request at page 117

Esempi di accessori disponibili su richiesta a pagina 117



90° leg inclination / Inclinazione gambe a 90°



Seat guides version / Versione con guide seduta

COD. 1217

Dentamed is equipped with high-performance and silent electronics and a practical standard foot pedal control. The shape of the backrest is designed to approach the patient face and the base size is suitable also for small rooms.

IDEAL FOR: dental, diagnostics, ENT and ophthalmic examinations.

Dentamed è dotata di elettronica altamente performante e silenziosa e di una pratica pedaliera standard. La forma dello schienale è studiata per avvicinarsi al volto del paziente e l'ingombro della base è idoneo anche per le stanze piccole.

IDEALE PER: visite dentali, diagnostiche, ORL e oftalmologiche.

** The images are for illustrative purposes only and may not reflect the actual image of the finishing.*

** Le immagini hanno valore puramente illustrativo e possono non rispecchiare l'immagine reale della finitura.*

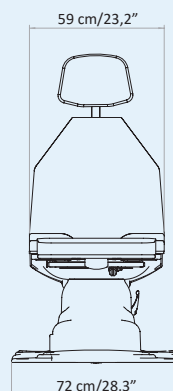
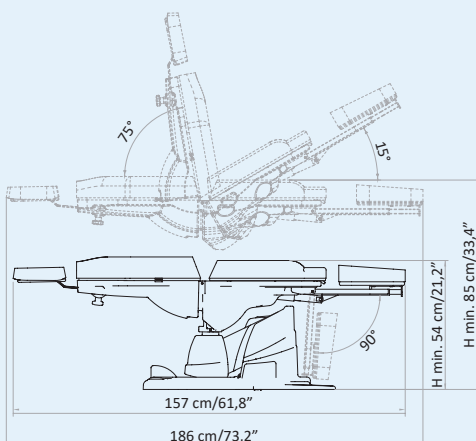

Packaging details

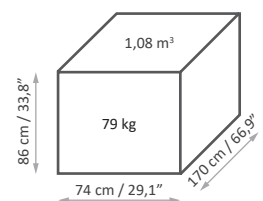

MAXIMUM CAPACITY
PORTATA MASSIMA

200 kg

STANDARD CONTROL

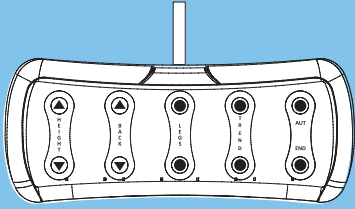

4 ELECTRIC MOTORS



M1 - MEMORY FUNCTION



AUT FUNCTION



SYNCHRO FUNCTION



Easy-to-clean anatomic mattress without stitching
Materasso anatomico senza cuciture per una facile igienizzazione

54-85 cm
(21,2"-33,4")

Electric height
Altezza elettrica



Electric Trendelenburg
Trendelenburg elettrico



Version with seat guides
Versione con guide seduta



90° rotation on both sides
Rotazione 90° da entrambi i lati

COMANDO STANDARD

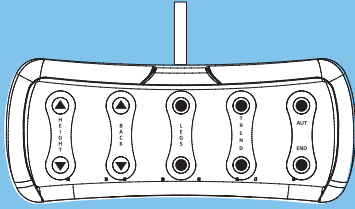

4 MOTORI
ELETTRICI



M1 - FUNZIONE
MEMORIE



FUNZIONE
AUT



FUNZIONE
SYNCHRO



111

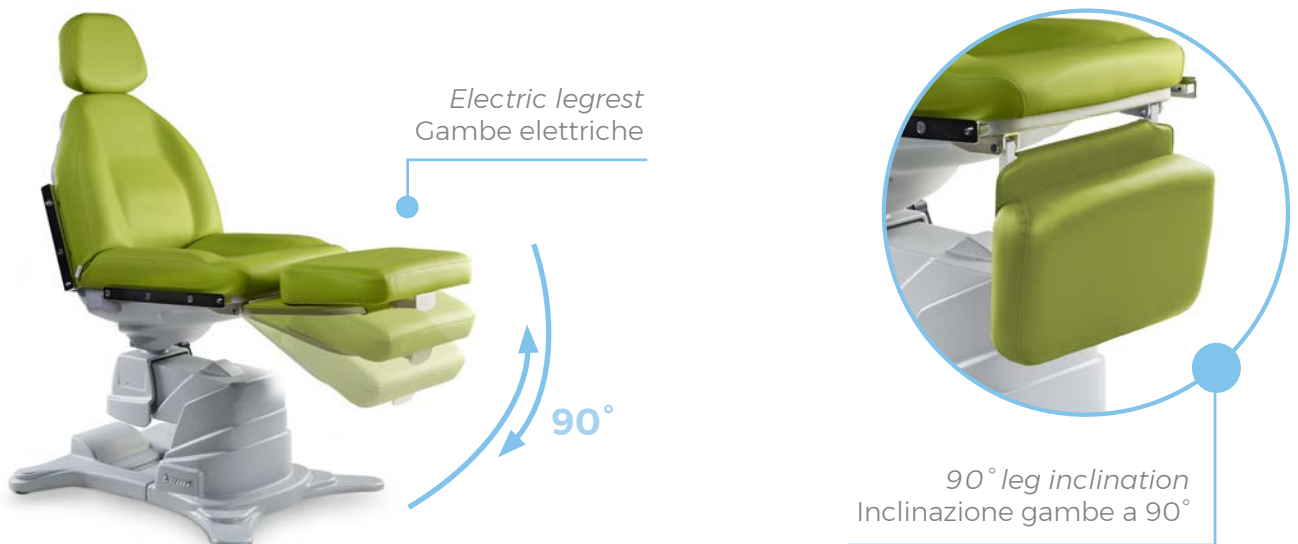

DENTAMED MOVE



112

* M: Nefos 1868

Version with ophthalmology head and seat guides / Versione con testa oftalmologica e guide seduta

Focus on

▪ Standard foot pedal control with 1 MEMORY function **NEW**

- AUT function: automatic return to the original position (chair)
- SYNCHRO function: synchronized backrest/legrest movement (ONLY by handset control)
- Fire retardant class 1IM, "Azo" free, antibacterial, antifungal covering

▪ Standard version includes: 4 electric motors (height, back, leg, trendelenburg adjustment), foot pedal control, "Easy-to-clean" seamless anatomic mattress with Zak headrest, MOVE base with integrated wheels, back guides

▪ Pedaliera standard con 1 funzione MEMORIE **NEW**

- Funzione AUT: ritorno automatico alla posizione base (poltrona)
- Funzione SYNCHRO: movimento schiena/gambe sincronizzato (SOLO con pulsantiera)
- Rivestimento ignifugo classe 1IM, "Azo" free, antibatterico, antimicotico

▪ La versione standard include: 4 motori elettrici (regolazione altezza, schienale, gamba, trendelenburg), pedaliera, materasso anatomico senza cuciture "easy-to-clean" con testa Zak, base MOVE con ruote integrate, guide schiena

On demand

Examples of accessories available upon request at page 117

Esempi di accessori disponibili su richiesta a pagina 117



Ophthalmology headrest / Testa oftalmologica



COD. 1218

Dentamed Move is equipped with high-performance and silent electronics and a practical standard foot pedal control. The shape of the backrest is designed to approach the patient face. The move base helps with cleaning and disinfection of medical environments and the base size is suitable also for small rooms.

IDEAL FOR: dental, diagnostics, ENT and ophthalmic examinations.

Dentamed Move è dotata di elettronica altamente performante e silenziosa e di una pratica pedaliera standard. La forma dello schienale è studiata per avvicinarsi al volto del paziente. La base MOVE facilita la pulizia e disinfezione dell'ambiente medico e l'ingombro della base è idoneo anche per le stanze piccole.

IDEALE PER: visite dentali, diagnostiche, ORL e oftalmologiche.

** The images are for illustrative purposes only and may not reflect the actual image of the finishing.*

** Le immagini hanno valore puramente illustrativo e possono non rispecchiare l'immagine reale della finitura.*

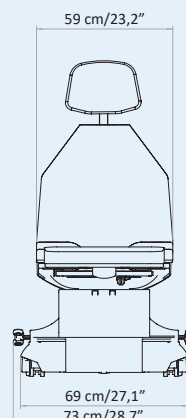
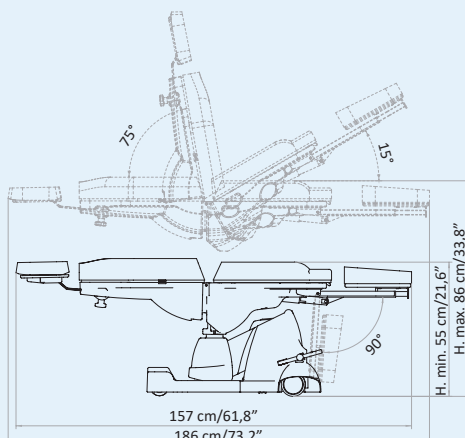

Packaging details

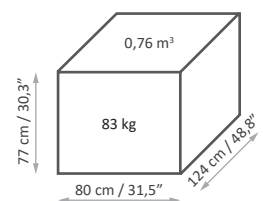

MAXIMUM CAPACITY
PORTATA MASSIMA



200 kg

STANDARD CONTROL

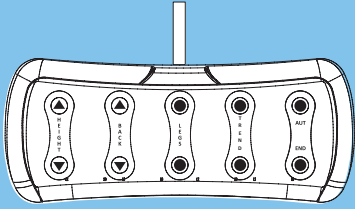

4 ELECTRIC MOTORS



M1 - MEMORY FUNCTION



AUT FUNCTION



SYNCHRO FUNCTION



55-86 cm
(21,6"-33,8")

Easy-to-clean anatomic mattress without stitching
Materasso anatomico senza cuciture per una facile igienizzazione



Electric height
Altezza elettrica



15°

Electric Trendelenburg
Trendelenburg elettrico

Version with ophthalmology head and seat guides
Versione con testa oftalmologica e guide seduta

COMANDO STANDARD

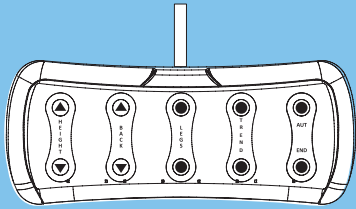

4 MOTORI
ELETTRICI



M1 - FUNZIONE
MEMORIE



FUNZIONE
AUT



FUNZIONE
SYNCHRO



MOVE base with integrated wheels
Base MOVE con ruote integrate

Front wheels: Ø100 cm with brake
Rear wheels: Ø80 cm without brake
Ruote anteriori: Ø100 cm con freno
Ruote posteriori: Ø80 cm senza freno

75°

Electric backrest
Schiena elettrica



Electric legrest
Gambe elettriche

90°

90° leg inclination
Inclinazione gambe a 90°



LEMI STANDARD

Choose the medical chair with STANDARD CONFIGURATION by LEMI
Scegli la poltrona medica con la CONFIGURAZIONE STANDARD by LEMI

DREAMED ZAK



1
ZAK
HEADREST

4
BACK GUIDES
COUPLE

2
180°
ROTATION

3
FOOT PEDAL
CONTROL

ZAK HEADREST TESTA ZAK

Adjustable and removable Zak headrest
Testa Zak regolabile ed estraibile

180° ROTATION ROTAZIONE 180°

Function that optimizes working space of the
medical room
Funzione che ottimizza la gestione dello spazio
nello studio medico

FOOT PEDAL CONTROL PEDALIERA

Practical foot pedal control for chair adjustment
Pratica pedaliera per regolazione poltrona

BACK GUIDES COUPLE COPPIA GUIDE SCHIENA

Back guides for accessories
Guide schiena per accessori

ACCESSORIES UPON REQUEST ACCESSORI SU RICHIESTA

Customize the medical chair with the ACCESSORIES available on request.
Personalizza la poltrona medica con gli ACCESSORI disponibili su richiesta.

HEADS TESTE



Strip headrest (only for Bi-Zak)
Testa strip (solo per Bi-Zak)

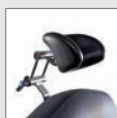

Anto headrest for hair transplant (only for Bi-Zak)
Testa Anto per trapianto capelli (solo per Bi-Zak)



Head support
Poggiatesta

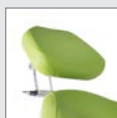

Ophthalmological headrest
Testa oftalmologica



Blood sample taking armrest couple (+ seat guides and fixed clamps)
Coppia braccioli da prelievo con snodo (+ guide seduta e morsetti fissi)

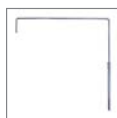

Curtain holder (+ back guides and rotating clamps)
Reggitelo (+ guide schiena e morsetti girevoli)



Thigh support couple (+ seat guides and fixed clamps)
Coppia reggicoscce con snodo (+ guide seduta e morsetti fissi)



Wheels with brake (ø 50mm)
Ruote con freno (ø 50mm)

NEW



Roll Holder (66 cm)
Portarotolo (66 cm)



Seat guide couple
Coppia guide seduta



Cushion between seat and legrest
Cuscino tra seduta e gamba



Clamps couple (fixed/rotating)
Coppia morsetti (fissi/girevoli)



I.V. Rod
Asta portaflebo



Medical armrest couple (+ back guides and rotating clamps)
Coppia braccioli medicali (+ guide schiena e morsetti girevoli)



Handset control with memories function
Pulsantiera con funzione memorie



Wireless foot pedal control with memories (NO foot pedal with cable NO remote control)
Pedaliera wireless con memorie (NON compatibile con il pedale a filo e con la pulsantiera)



Plastic leg protection
Proteggi gambe in plastica



Inox tray with support (+ seat guides and fixed clamps)
Vassoio inox completo di telaio (+ guide seduta e morsetti fissi)



Mattress with customised LOGO
Materasso con LOGO personalizzato

The images are for illustrative purposes only and may not reflect the actual image of the product.
Le immagini hanno valore puramente illustrativo e possono non rispecchiare l'immagine reale del prodotto.

LEMI MATTRESSES

The MATTRESSES of the LEMI MEDICAL line are made with the best quality materials to ensure maximum comfort for both the patient and the doctor.



DREAMED

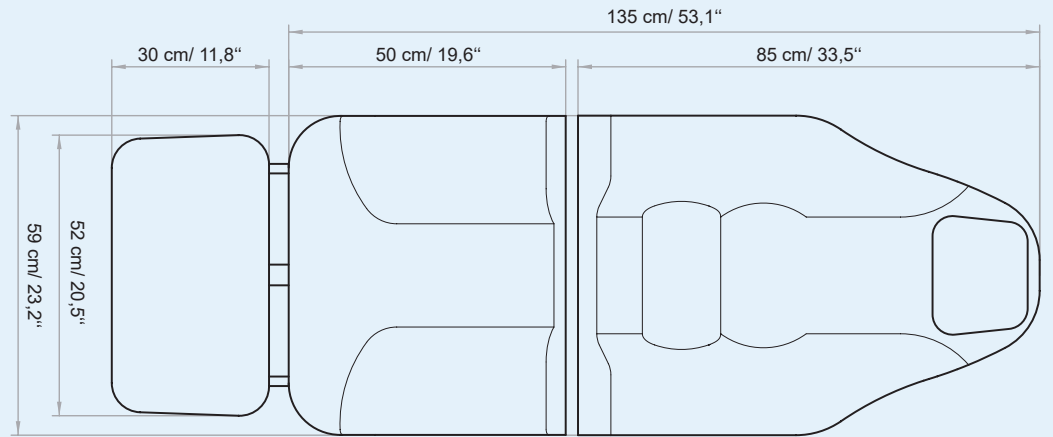

THICKNESS
SPESSORE
9cm | 3,5"



DENTAMED

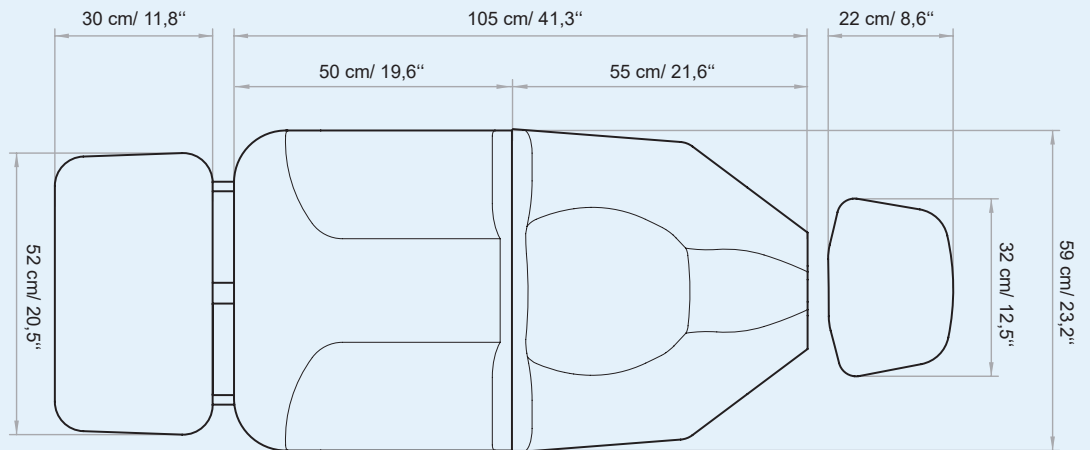

THICKNESS
SPESSORE
9 / 12cm
3,5" / 4,7"



MATERASSI LEMI

I MATERASSI della linea MEDICALE LEMI sono realizzati con materiali della migliore qualità per garantire il massimo comfort sia per il paziente che per il medico.

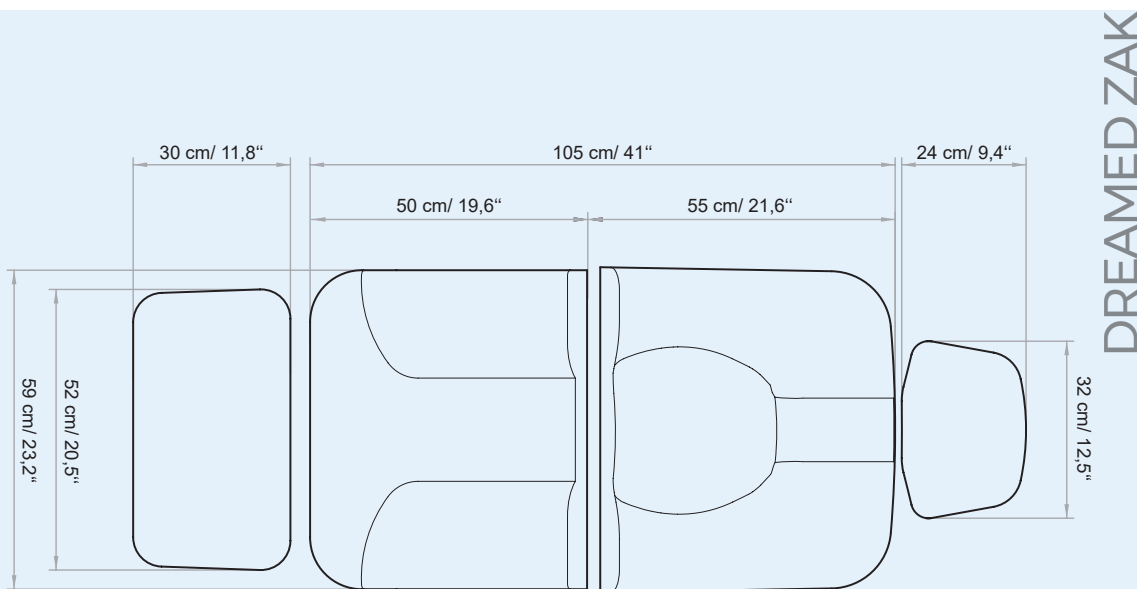

DREAMED ZAK



THICKNESS
SPESSORE
9cm | 3,5"

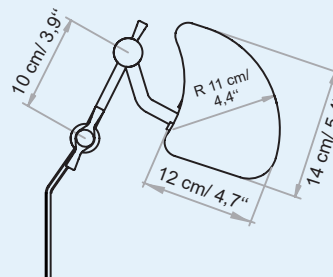
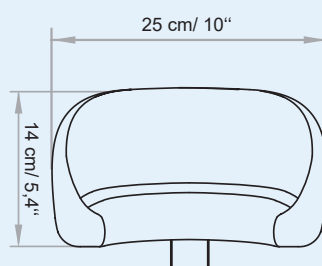
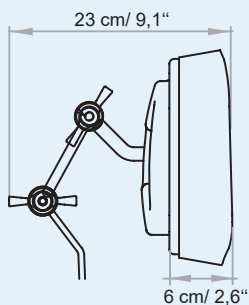
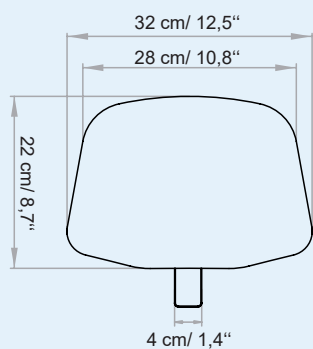
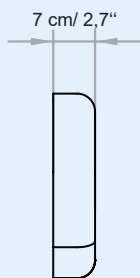
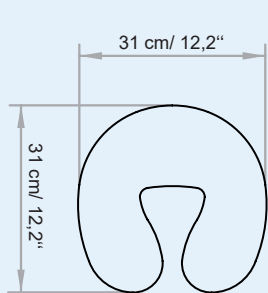

HEADS

STRIP



OPHTHALMOLOGICAL



ANTO







TRICHOLOGY

TRICCOLOGIA

HAIR TRANSPLANT
TRAPIANTO CAPELLI



122

* M: Nefos 991

Versione standard / Standard version

Focus on

- **Standard handset control with 1 MEMORY function** **NEW**
- **AUT function:** automatic return to the original position (chair)
- **SYNCHRO function:** synchronized backrest/legrest movement (ONLY by handset control)
- **Fire retardant class 1IM, "Azo" free, antibacterial, antifungal covering**
- **Entirely enclosed ABS casing**
- **Fully customizable**
- **Standard version includes: Bi-Zak mattress without stitching and with memory foam (extra comfort), flat armrests, manually adjustable headrest and footrest, Strip headrest and Anto headrest**

- **Pulsantiera standard con 1 funzione MEMORIE** **NEW**
- **Funzione AUT:** ritorno automatico alla posizione base (poltrona)
- **Funzione SYNCHRO:** movimento schiena/gambe sincronizzato (SOLO con pulsantiera)
- **Rivestimento ignifugo classe 1IM, "Azo" free, antibatterico, antimicotico**
- **Carter in ABS completamente chiuso**
- **Totalmente personalizzabile**
- **La versione standard include: materasso Memory (extra comfort) Bi-Zak senza cuciture, pulsantiera, braccioli automatici, testa e piedi regolabili manualmente, testa Strip e testa Anto**

On demand

Examples of accessories available upon request at page 127

Esempi di accessori disponibili su richiesta a pagina 127

HAIR TECH UPGRADE



COD. 1163

Hair-Tech is equipped with high-performance and silent electronics and a practical standard handset control. Strip headrest for follicle extraction and Anto headrest for cervical support. The extremely soft mattress makes Hair-Tech ideal for long sessions.

IDEAL FOR: trichology.

Hair-Tech è dotata di elettronica altamente performante e silenziosa e di una pratica pulsantiera standard. Poggiatesta Strip per l'estrazione del follicolo e poggiatesta Anto per il supporto cervicale. Il materasso estremamente morbido rende Hair-Tech ideale per lunghe sedute.

IDEALE PER: tricologia.



**Strip headrest
Testa Strip**



**Standard Anto headrest
Testa Anto standard**

** The images are for illustrative purposes only and may not reflect the actual image of the finishing.*

** Le immagini hanno valore puramente illustrativo e possono non rispecchiare l'immagine reale della finitura.*

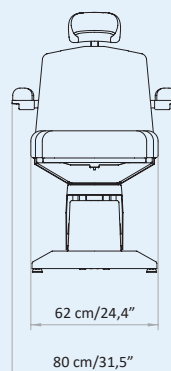
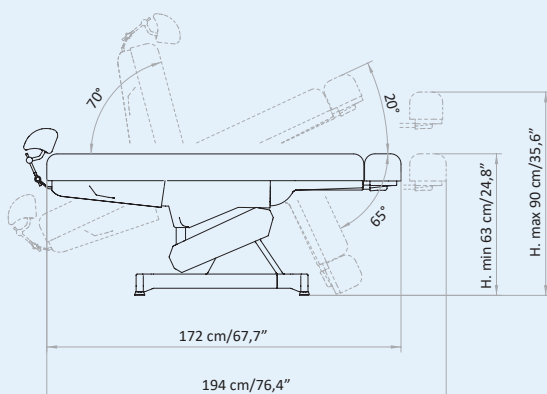

Packaging details

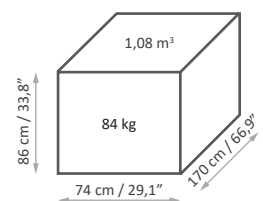

MAXIMUM CAPACITY
PORTATA MASSIMA

200 kg

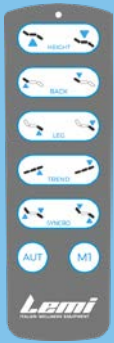

STANDARD CONTROL



4 ELECTRIC MOTORS



M1 - MEMORY FUNCTION



AUT FUNCTION



SYNCHRO FUNCTION



Strip headrest is suitable for the extraction of hair follicles

La testa Strip è idonea al prelievo dei follicoli

63-90 cm
(24,8"-35,6")

Electric height
Altezza elettrica

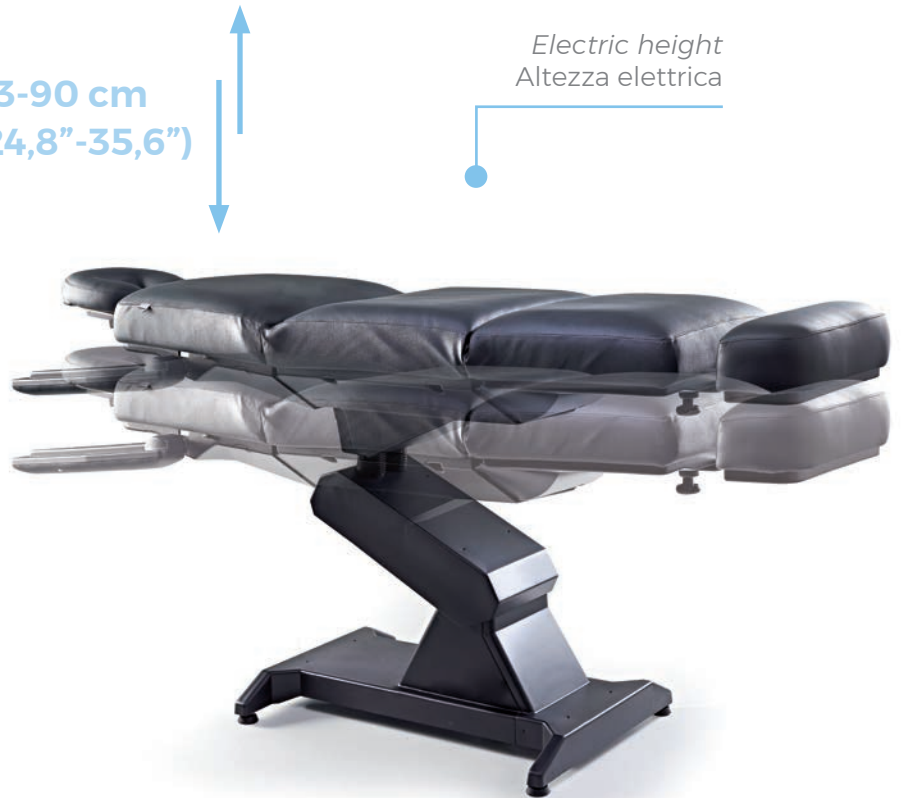

20°

Electric Trendelenburg
Trendelenburg elettrico



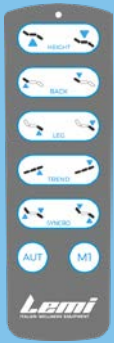

COMANDO STANDARD



4 MOTORI
ELETTRICI



M1 - FUNZIONE
MEMORIE



FUNZIONE
AUT



FUNZIONE
SYNCHRO



Electric backrest
Schiena elettrica

70°



Synchronized backrest/legrest movement
Movimento sincronizzato schiena/gambe

ONLY by handset control
SOLO con pulsantiera

Electric legrest
Gambe elettriche

65°



LEMI STANDARD

Choose the medical chair with STANDARD CONFIGURATION by LEMI
Scegli il lettino medicale con la CONFIGURAZIONE STANDARD by LEMI

HAIRTECH



1
ANTO
HEADREST

2
EXTRA-COMFORT
MATTRESS

4
FLAT
ARMRESTS

3
HANDSET
CONTROL

ANTO HEADREST TESTA ANTO

Specific head for hair transplant
Testa specifica per trapianto capelli

EXTRA-COMFORT MATTRESS MATERASSO EXTRA-COMFORT

The padding guarantees extra comfort for the entire session
L'imbottitura garantisce extra comfort per tutta la durata della seduta

HANDSET CONTROL PULSANTIERA

Practical handset control for chair adjustment
Pratica pulsantiera per regolazione poltrona

FLAT ARMRESTS BRACCIOLI AUTOMATICI

Couple of flat armrests
Coppia di braccioli automatici

ACCESSORIES UPON REQUEST ACCESSORI SU RICHIESTA

Customize the HAIR TECH chair with the ACCESSORIES available on request.
Personalizza la poltrona HAIR TECH con gli ACCESSORI disponibili su richiesta.

MATTRESS MATERASSI

XL

Mattress XL
Materasso XL

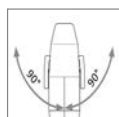

Option 180° rotation
Opzione rotazione 180°



Roll Holder (66 cm)
Roll Holder (75 cm) for XL mattress
Portarotolo (66 cm)
Portarotolo (75 cm) per materassi XL



Plastic leg protection
Proteggi gambe in plastica



Seat guide couple
Coppia guide seduta



Inox tray with support
(+ seat guides and fixed clamps)
Vassoio inox completo di telaio
(+ guide seduta e morsetti fissi)



Fixed clamp
Morsetto fisso



Mattress with customised LOGO
Materasso con LOGO personalizzato



Wheels with brake (ø 50mm)
Ruote con freno (ø 50mm)

NEW



Foot pedal control with memories function
Pedaliera con funzione memorie



Wireless foot pedal control with memories function
(NO foot pedal with cable NO remote control)
Pedaliera wireless con funzione memorie
(NON compatibile con il pedale a filo e con la pulsantiera)

LEMI MATTRESSES

The MATTRESSES of LEMI MEDICAL line are made with the best quality materials to ensure maximum comfort for both the patient and the doctor.



MEMORY - HAIR TECH

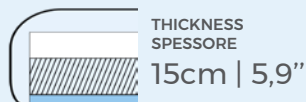
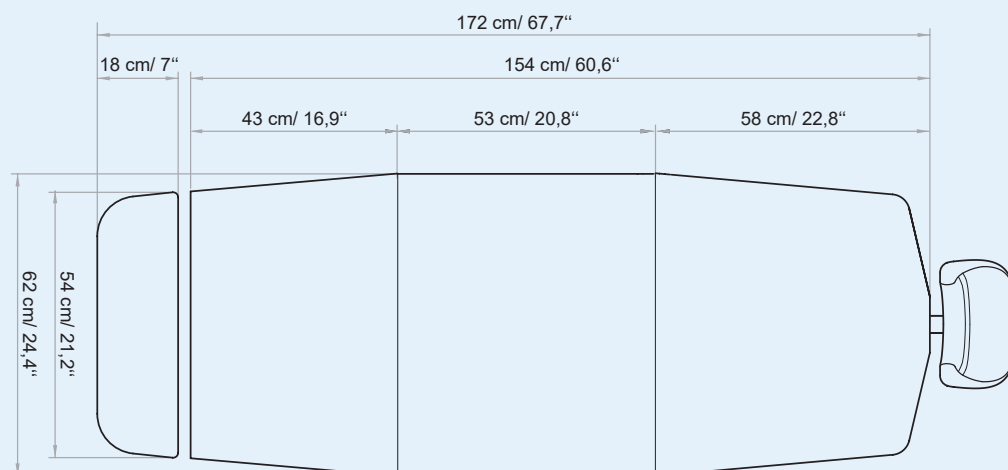

MEMORY FOAM MATTRESS

Super Soft Mattress in Memory Foam

Thickness: 15 cm / 5,9"

The Memory Foam mattress allows an optimal comfort for the patient even for long-lasting treatments. Furthermore, with the handset control supplied, the patient can independently adjust the chair to find the most comfortable position.

Materasso Super Soft in Memory Foam

Spessore: 15 cm

Il materasso in Memory Foam permette un comfort ottimale del paziente anche per trattamenti di lunga durata. Inoltre con la pulsantiera in dotazione il paziente può regolare in autonomia la poltrona trovando la posizione più comoda.

MATERASSI LEMI

I MATERASSI della linea MEDICALE LEMI sono realizzati con materiali della migliore qualità per garantire il massimo comfort sia per il paziente che per il medico.

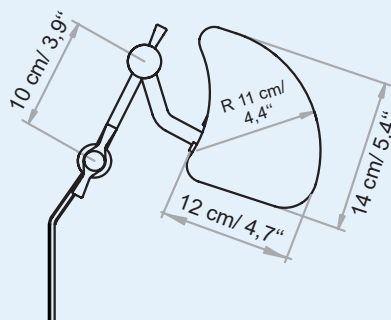
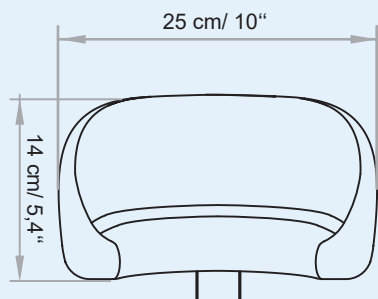

ANTO - HEAD

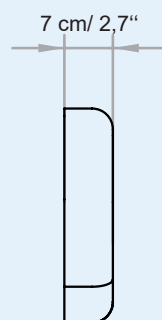
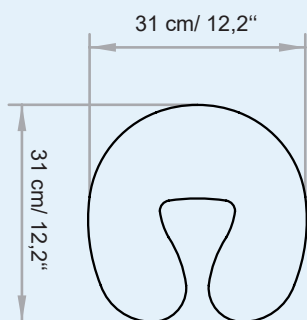

STRIP - HEAD



Adjustable and removable footrest
Piede regolabile ed estraibile

Adjustable Anto headrest
Testa Anto regolabile







GYNAECCOLOGY

GINECCOLOGIA

GYNO PLUS



* M: Nefos 680

Focus on

- 3 electric motors for height, back and tilting adjustment
- Seat with hole
- Standard pedal control with 2 options for MEMORY function
- AUT function: "End of treatment" position **NEW**
- END function: automatic return from any position to zero position (flat and minimum height)
- Fire retardant class 1IM, "Azo" free, antibacterial, antifungal covering
- 90° rotation on both sides
- Standard version includes: stainless steel basin, thigh support couple, seat guides couple, fixed clamps couple, stainless steel handles and roll holder

- 3 motori elettrici per regolazione di altezza, schiena e basculante
- Seduta con foro
- Pedaliera standard con 2 opzioni di funzione MEMORIE
- Funzione AUT: posizione "fine del trattamento" **NEW**
- Funzione END: ritorno automatico da ogni posizione alla posizione zero (piatto e altezza minima)
- Rivestimento ignifugo classe 1IM, "Azo" free, antibatterico, antimicotico
- Rotazione di 90° da entrambi i lati
- La versione standard include: bacinella in acciaio inossidabile, coppia di reggiosce, coppia guide seduta, coppia morsetti fissi, maniglie in acciaio inossidabile e porta rotolo

On demand

Examples of accessories available upon request at page 145

Esempi di accessori disponibili su richiesta a pagina 145

GYNO PLUS UPGRADE

COD. 828

The anatomic mattress with HOLE of Gyno Plus has been specifically designed to meet ergonomic needs during gynaecology and urology sessions. Thanks to its minimum height of 54 cm and very precise adjustment of several positions, it ensures maximum ease of access for patients and, at the same time, offers ideal functionality for the doctor. The ample hole in the front area has a rounded shape, so that the doctor can easily operate. Manual legrest available upon request.

Il materasso anatomico CON FORO di Gyno Plus è stato appositamente studiato per rispondere alle esigenze ergonomiche durante le visite ginecologiche ed urologiche. Grazie alla sua altezza minima di 54 cm e alla regolazione molto precisa di più posizioni, Gyno Plus garantisce la massima facilità di accesso ai i pazienti e, allo stesso tempo, offre la funzionalità ideale per il medico. L'ampio foro nella zona anteriore presenta una sagoma arrotondata per dare al medico la possibilità di operare agevolmente. Gamba manuale disponibile su richiesta.



Wide seat hole / Ampio foro seduta



Version with manual legrest / Versione con gambe estraibile

* The images are for illustrative purposes only and may not reflect the actual image of the finishing.

* Le immagini hanno valore puramente illustrativo e possono non rispecchiare l'immagine reale della finitura.

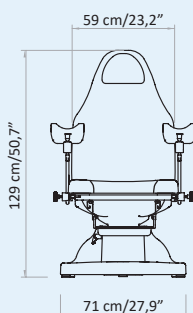
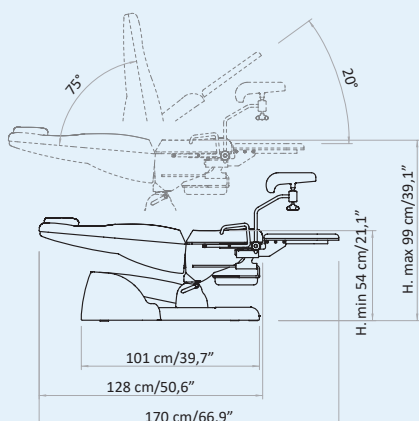

Packaging details

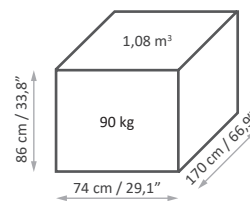

MAXIMUM CAPACITY
PORTATA MASSIMA



200 kg

MOVEMENTS

3 independent electric movements: height, back and trendelenburg

1 manual movement: leg support fixation

AUT: automatic reset control to bring the chair back to the initial position

END: automatic return from any position to zero position (flat and minimum height)

Standard pedal control with 2 options for MEMORY function

Chair rotation 180°

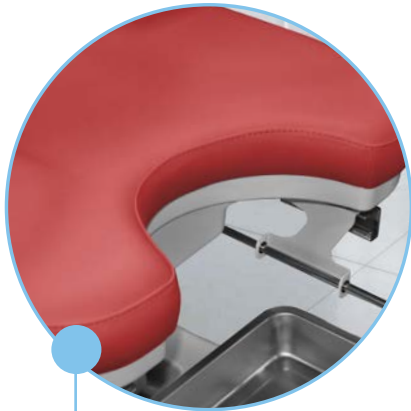

Wide seat hole
Ampio foro seduta

54-99 cm
(21,1" - 39,1")



Electric height
Altezza elettrica



20°

Electric Trendelenburg
Trendelenburg elettrico

MOVIMENTI

3 movimenti elettrici indipendenti: altezza, schiena e trendelenburg

1 movimento manuale: inserimento supporto gamba

AUT: comando di azzeramento automatico che riporta la poltrona nella posizione base

END: ritorno automatico da ogni posizione alla posizione zero (piatto e altezza minima)

Pedaliera standard con 2 opzioni di funzione MEMORIE

Rotazione poltrona 180°

90° rotation on both sides
Rotazione 90° da entrambi i lati



Electric backrest
Schiena elettrica

75°

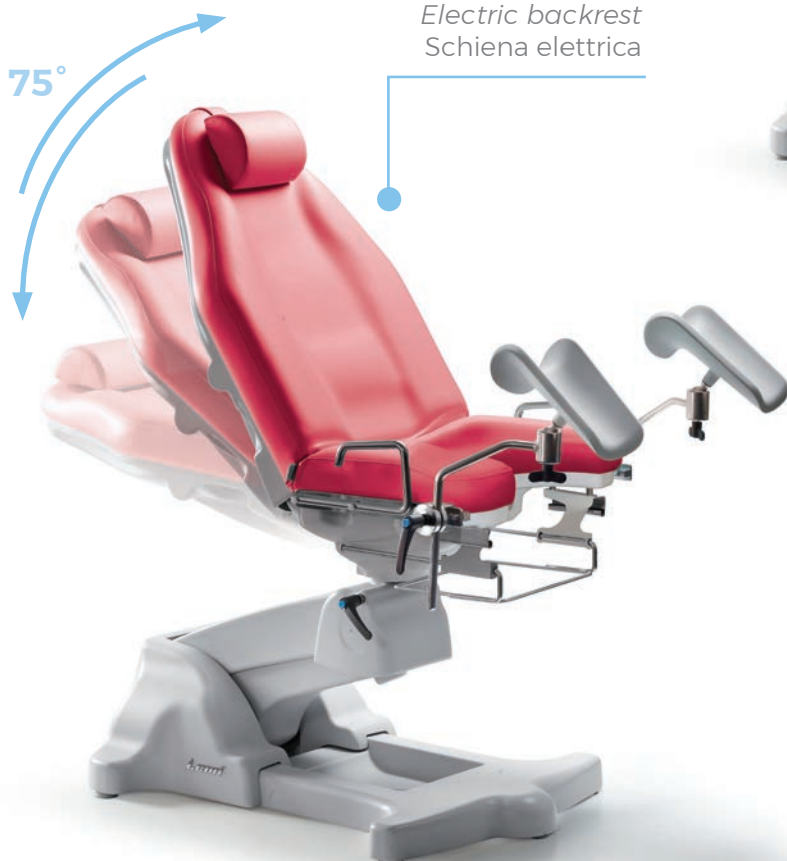

Large removable stainless steel bowl
27 x 33 x 5 h cm - 10,6" x 12,9" x 1,9" h

Ampia bacinella in acciaio inox estraibile
27 x 33 x 5 h cm - 10,6" x 12,9" x 1,9" h





136

* M: Nefos 6

Standard version with thigh support couple / Versione standard con coppia di reggicose Stool 010/S

Focus on

- Standard handset control with 2 MEMORY functions
- END function: automatic return to flat position (flat and minimum height) **NEW**
- AUT function: automatic return to the original position (chair)
- Fire retardant class 1IM, "Azo" free, antibacterial, antifungal covering
- Entirely enclosed ABS casing
- Fully customizable
- Standard version includes: 3 electric motors (height, back, trendelenburg adjustment), foot pedal control and anatomic mattress, stainless steel basin, thigh support couple, seat guides couple, fixed clamps couple, stainless steel handles and roll holder

On demand

Examples of accessories available upon request at page 145

- Pedaliera standard con 2 funzioni MEMORIE
- Funzione END: ritorno automatico alla posizione piatta (piatto e altezza minima) **NEW**
- Funzione AUT: ritorno automatico alla posizione base (poltrona)
- Rivestimento ignifugo classe 1IM, "Azo" free, antibatterico, antimicotico
- Carter in ABS completamente chiuso
- Totalmente personalizzabile
- La versione standard include: 3 motori elettrici (regolazione altezza, schiena e trendelenburg), pedaliera e materasso anatomico, vaschetta in acciaio inossidabile, coppia di reggicose, coppia guide seduta, coppia morsetti fissi, maniglie in acciaio inossidabile e portarotolo

Esempi di accessori disponibili su richiesta a pagina 145



Version with manual legrest / Versione con gamba manuale

Seat hole with a practical stainless steel bowl
Seduta con foro e pratica vaschetta inox**COD. 1159**

Lemi Gyno is equipped with high-performance and silent electronics and a practical standard foot pedal control. Upon request, the version with manual legrest allows the chair to become a functional examination bed. Anatomic mattress with wide customization.

IDEAL FOR: diagnostics, gynecological, ultrasound and colposcopic examinations

Lemi Gyno è dotata di elettronica altamente performante e silenziosa e di una pratica pedaliera standard. Su richiesta, la versione con gamba manuale consente alla poltrona di diventare un lettino funzionale. Materasso anatomico con ampia possibilità di personalizzazione.

IDEALE PER: esami diagnostici, ginecologici, ecografici e colposcopici.

** The images are for illustrative purposes only and may not reflect the actual image of the finishing.*

** Le immagini hanno valore puramente illustrativo e possono non rispecchiare l'immagine reale della finitura.*

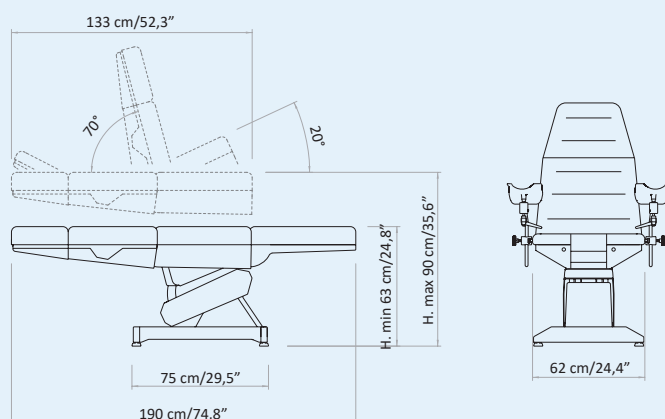
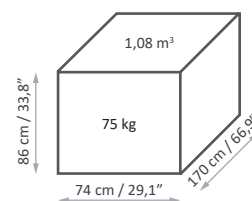
**Packaging details**

MAXIMUM CAPACITY
PORTATA MASSIMA



200 kg

STANDARD CONTROL

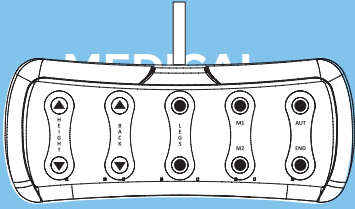

3 ELECTRIC MOTORS



M1 - M2 MEMORY FUNCTION



AUT FUNCTION



END FUNCTION



Seat hole with a practical stainless steel bowl
16,3 x 10,3 x 4,4h cm - 6,4" x 4" x 1,7" h
Seduta con foro e pratica vaschetta inox
16,3 x 10,3 x 4,4h cm - 6,4" x 4" x 1,7" h

63-90 cm
(24,8" - 35,6")

Electric height
Altezza elettrica



70°

Electric backrest
Schiena elettrica



COMANDO STANDARD

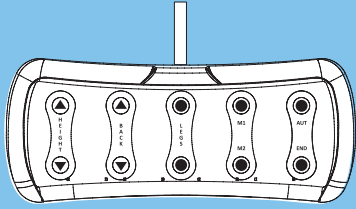

3 MOTORI
ELETTRICI



M1 - M2 FUNZIONI
MEMORIE



FUNZIONE
AUT



FUNZIONE
END



Electric Trendelenburg
Trendelenburg elettrico

139



*Manual legrest available upon request
to get the bed position*
Gamba manuale a richiesta per ottenere
la posizione lettino

HYDROGYNO



140

* M: Nefos 6

Standard version with thigh support couple / Versione standard con coppia di reggicosce

Focus on

- Hydraulic lift for height adjustment
- Manual backrest and trendelenburg adjustment
- 360° rotation
- "Easy-to-clean" mattress with seat hole
- Fire retardant class 1IM, "Azo" free, antibacterial, antifungal covering
- Manual legrest available upon request
- **Standard version includes: stainless steel basin, thigh support couple, seat guides couple, fixed clamps couple, stainless steel handles and roll holder**
- Pompa idraulica per la regolazione dell'altezza
- Regolazione manuale di schiena e trendelenburg
- Rotazione 360°
- Materasso "easy-to-clean" con foro seduta
- Rivestimento ignifugo classe 1IM, "Azo" free, antibatterico, antimicotico
- Gamba manuale disponibile su richiesta
- **La versione standard include: vaschetta in acciaio inossidabile, coppia di reggicosce, coppia guide seduta, coppia morsetti fissi, maniglie in acciaio inossidabile e portarotolo**

On demand

Examples of accessories available upon request at page 145

Esempi di accessori disponibili su richiesta a pagina 145

COD. 301

Hydrogyno is specifically designed for diagnostics, gynecological, ultrasound and colposcopic examinations. Equipped with standard anatomic mattress. Upon request, the version with manual legrest allows the chair to become a functional examination bed. Suitable for any kind of medical room partly thanks to 360° rotation.

Hydrogyno è la poltrona progettata per esami diagnostici, ginecologici e colposcopici. Dotato di materasso anatomico standard. Su richiesta, la versione con poggiamambe manuale consente alla poltrona di diventare un lettino funzionale. Indicato per ogni spazio medico anche grazie alla rotazione di 360°.



Version with manual legrest / Versione con gamba manuale



Hydraulic lift / Pompa idraulica

** The images are for illustrative purposes only and may not reflect the actual image of the finishing.*

** Le immagini hanno valore puramente illustrativo e possono non rispecchiare l'immagine reale della finitura.*

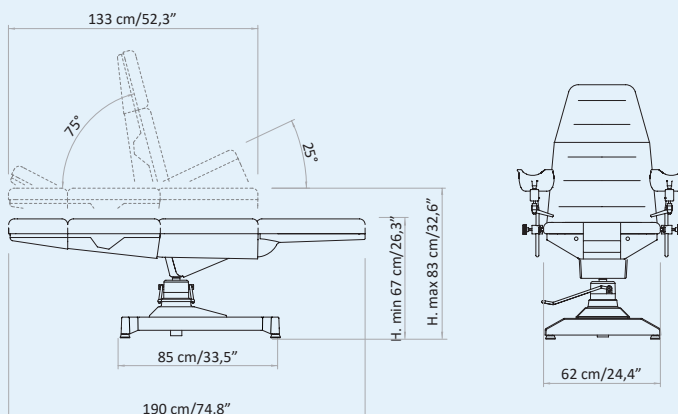

Packaging details

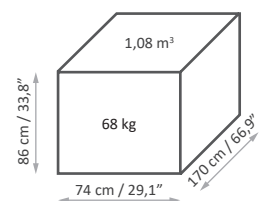

MAXIMUM CAPACITY
PORTATA MASSIMA

150 kg

MOVEMENTS

1 movement by hydraulic lift: height

3 manual movements: backrest, trendelenburg, manual legrest

360° chair rotation



Seat hole with a practical stainless steel bowl

16,3 x 10,3 x 4,4h cm - 6,4" x 4" x 1,7" h

Seduta con foro con pratica vaschetta inox

16,3 x 10,3 x 4,4h cm - 6,4" x 4" x 1,7" h

142



Manual Trendelenburg
Trendelenburg manuale

67-83 cm
(26,3"-32,6")

Height by hydraulic lift
Altezza con pompa idraulica



MOVIMENTI

1 movimento con pompa idraulica: altezza

3 movimenti manuali: schiena, trendelenburg, gamba manuale

Rotazione poltrona 360°



180° rotation on both sides
Rotazione 180° da entrambi i lati

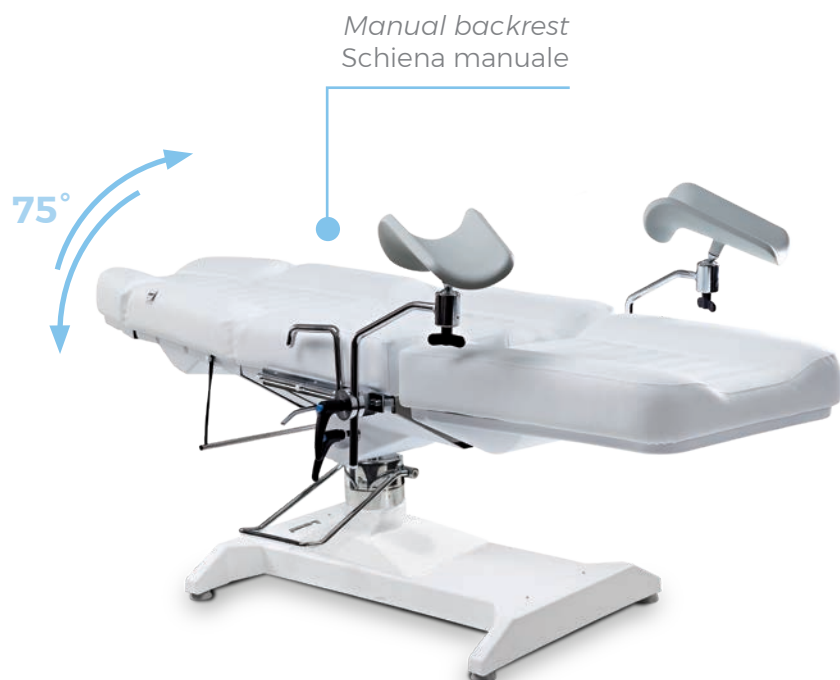

Manual backrest
Schiena manuale



Manual legrest
(upon request)
Gamba manuale
(su richiesta)

LEMI STANDARD

Choose the GYNECOLOGICAL chair with STANDARD CONFIGURATION by LEMI
Scegli la poltrona GINECOLOGICA con la CONFIGURAZIONE STANDARD by LEMI

GYNO PLUS



1
HEAD
SUPPORT

2
THIGH SUPPORT
COUPLE

4
FOOT PEDAL
CONTROL

3
INOX
BASIN

HEAD SUPPORT POGGIATESTA

Comfortable and adjustable headrest
Comodo poggiatesta regolabile

THIGH SUPPORT COUPLE COPPIA REGGICOSCE

Thigh support for gynecological line
Reggicosce per linea ginecologica

INOX BASIN VASCHETTA INOX

Large removable stainless steel bowl
Ampia bacinella in acciaio inox estraibile

FOOT PEDAL CONTROL PEDALIERA

Practical foot pedal control for chair adjustment
Pratica pedaliera per regolazione poltrona

ACCESSORIES UPON REQUEST ACCESSORI SU RICHIESTA

Customize the GYNECOLOGICAL chair with the ACCESSORIES available on request.
Personalizza la poltrona GINECOLOGICA con gli ACCESSORI disponibili su richiesta.

LEGS GAMBE



Leg support
Supporto gamba



Foot support couple
Coppia supporto piede



Back guide couple
Coppia guide schiena



Clamps couple
(fixed/rotating)
Coppia morsetti
(fissi/girevoli)



I.V. Rod
(+ back guides and rotating clamp)
Asta portaflebo
(+ guide schiena e morsetto girevole)



Medical armrest couple
(+ back guides and rotating clamps)
Coppia braccioli medicali
(+ guide schiena e morsetti girevoli)



Flat armrests couple
(only for Gyno Plus)
Coppia braccioli automatici
(solo per Gyno Plus)

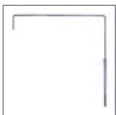

Curtain holder
(+ back guides and rotating clamps)
Reggitelo
(+ guide schiena e morsetti girevoli)



Inox tray with support
(+ seat guides and fixed clamps)
Vassoio inox completo di telaio
(+ guide seduta e morsetti fissi)



Wheels with brake (ø 50mm)
Ruote con freno (ø 50mm)



Wireless foot pedal control
(NO foot pedal with cable NO remote control)
Pedaliera wireless (NON compatibile con il
pedale a filo e con la pulsantiera)



Hanset control
Pulsantiera



Gyno lamp
Lampada Gyno



Colposcope supporto
Supporto colposcopio



Mattress with customised LOGO
Materasso con LOGO personalizzato

NEW

LEMI MATTRESSES

The MATTRESSES of LEMI MEDICAL line are made with the best quality materials to ensure maximum comfort for both the patient and the doctor.



GYNO PLUS

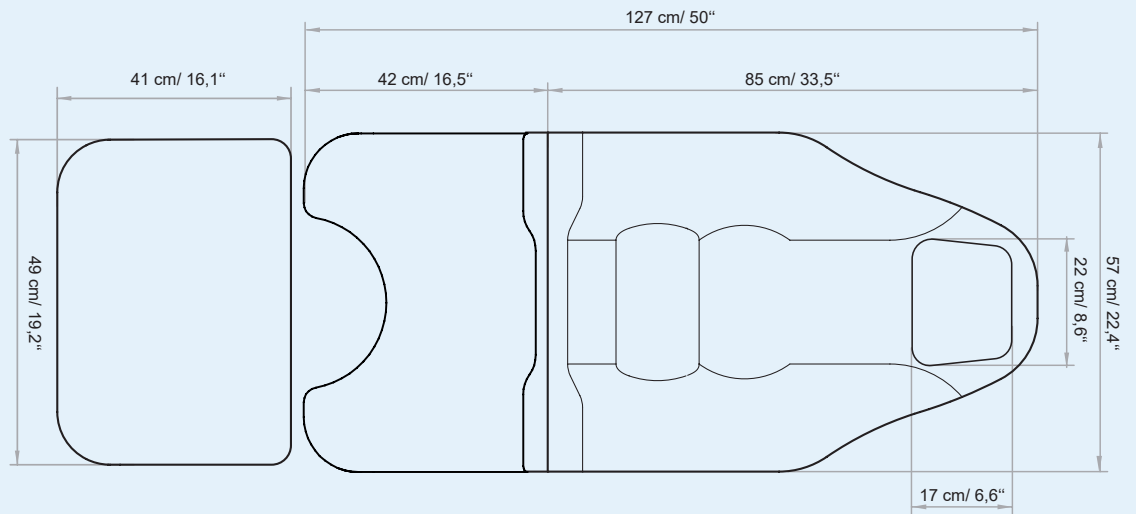

THICKNESS
SPESSORE
9cm | 3,5"



FOOT SUPPORT

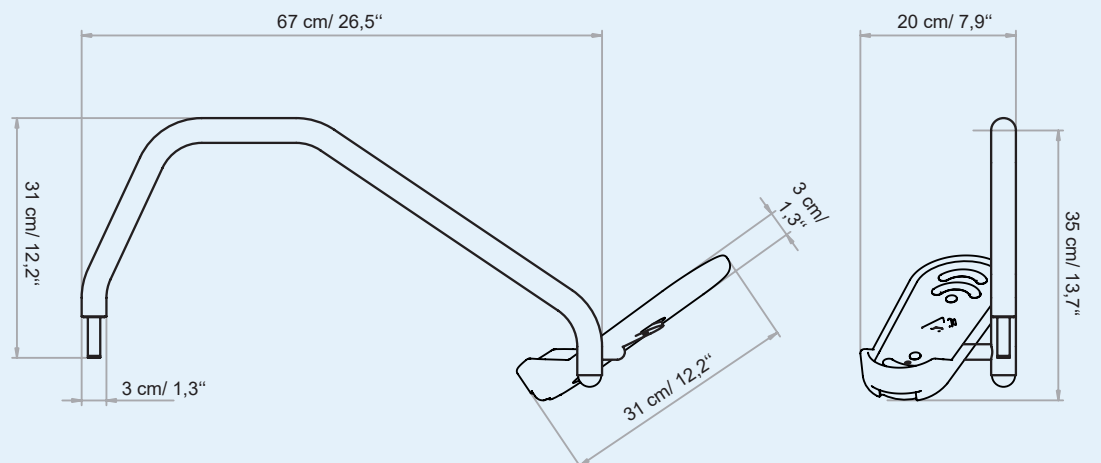

MATERASSI LEMI

I MATERASSI della linea MEDICALE LEMI sono realizzati con materiali della migliore qualità per garantire il massimo comfort sia per il paziente che per il medico.

GYN0

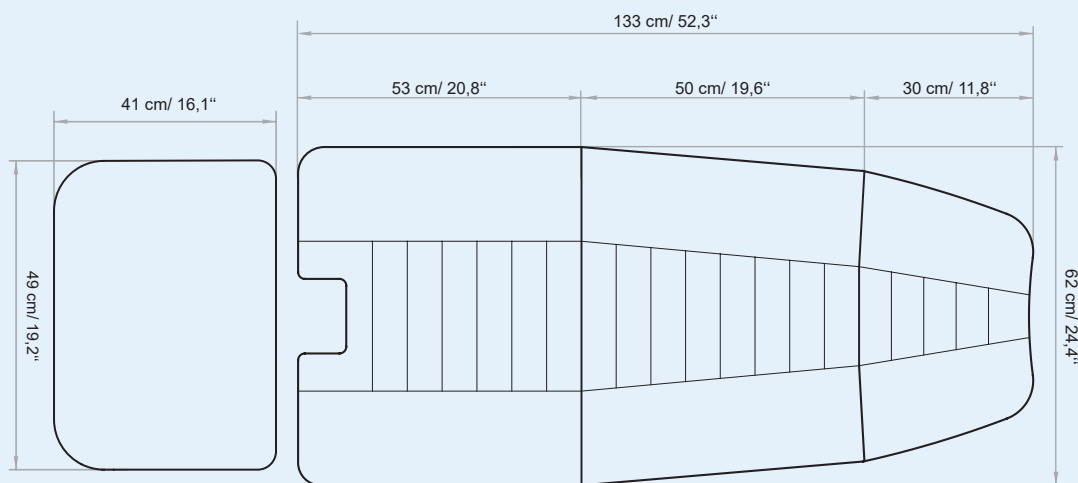

THICKNESS
SPESSORE
12cm | 4,7"

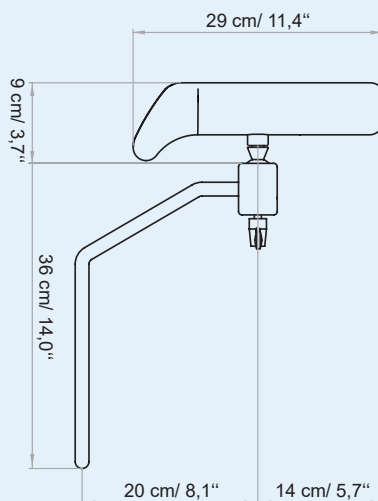
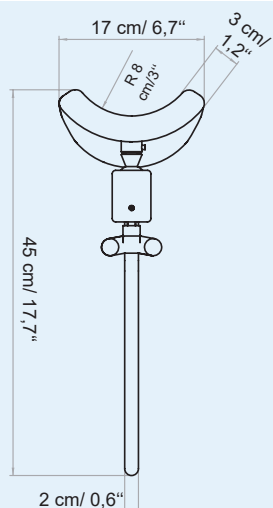

THIGH SUPPORT







DIAGNOSTICS
PHYSIOTHERAPY

DIAGNOSTICA
FISIOTERAPIA



150

* B: Beige | M: Nefos 6

Focus on

- Medical examination table
- 1 electric motor for height adjustment
- Gas spring for backrest adjustment
- Manually adjustable legrest
- Mattress complete with Zak headrest
- Extremely solid metal base
- Fire retardant class 1IM, "Azo" free, antibacterial, antifungal covering

- Lettino per visite mediche
- 1 motore elettrico per regolazione altezza
- Schienale regolabile mediante molla a gas
- Gamba regolabile manualmente
- Materasso completo di testa Zak estraibile
- Base metallica estremamente solida
- Rivestimento ignifugo classe 1IM, "Azo" free, antibatterico, antimicotico

On demand

Examples of accessories available upon request at page 163

Esempi di accessori disponibili su richiesta a pagina 163



COD. 1126

Featuring a reliable and solid metal base and a three sections mattress with Zak headrest, Sosul is suitable for diagnostics, rehabilitation, physiotherapy and reflexology treatments. Ensuring the utmost stability during medical examinations.

La base di metallo solida e affidabile a tre sezioni con testa Zak rende Sosul ideale per diagnostica, riabilitazione, fisioterapia e riflessologia. Garantisce una grande stabilità durante le visite mediche.

** The images are for illustrative purposes only and may not reflect the actual image of the finishing.*

** Le immagini hanno valore puramente illustrativo e possono non rispecchiare l'immagine reale della finitura.*

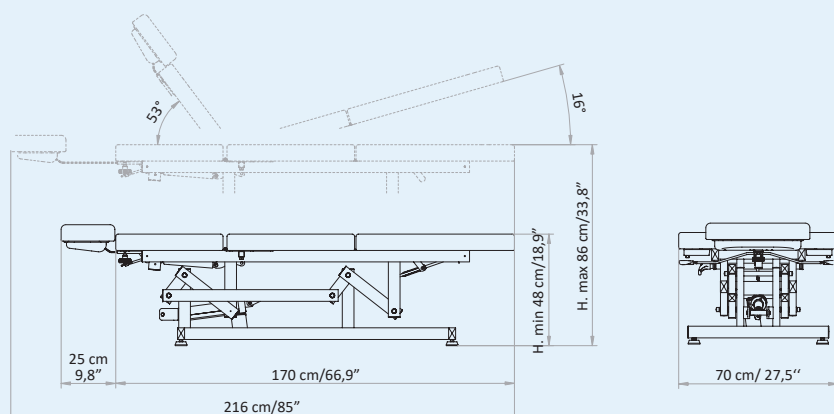

Packaging details

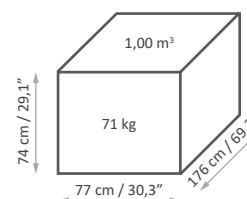

MAXIMUM CAPACITY
PORTATA MASSIMA

150 kg

MOVEMENTS

1 electric movement: height (very low: 48 cm/18,9")

3 manual movements: backrest (gas spring), seat and legrest inclination

Adjustable and removable Zak headrest



Three-section mattress
without stitching
Materasso a tre sezioni
senza cuciture

48-86 cm
(18,9"-33,8")

Electric height
Altezza elettrica



Manually adjustable seat with 5 inclinations
Seduta regolabile manualmente con 5 inclinazioni

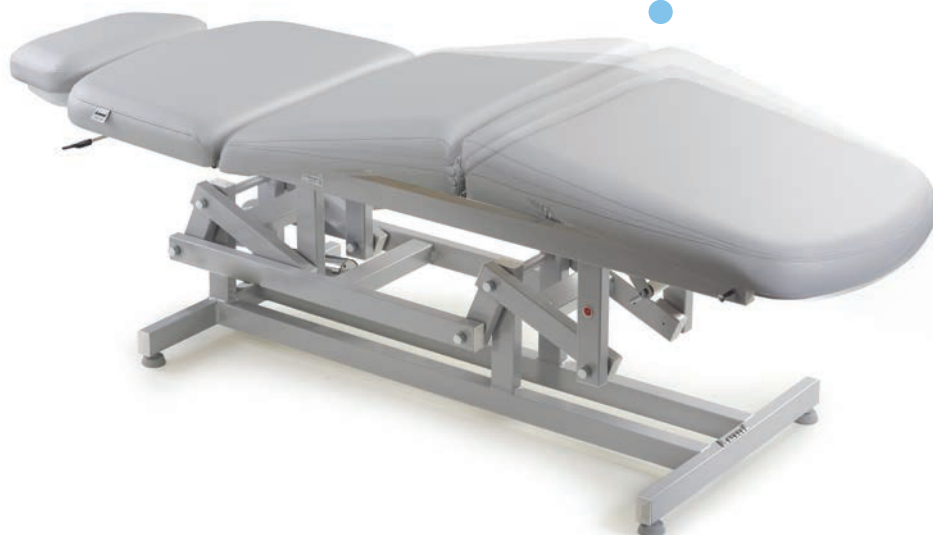

MOVIMENTI

1 movimento elettrico: altezza (molto basso: 48 cm)

3 movimenti manuali: schiena (molla a gas), inclinazione seduta e gamba

Testa Zak regolabile ed estraibile

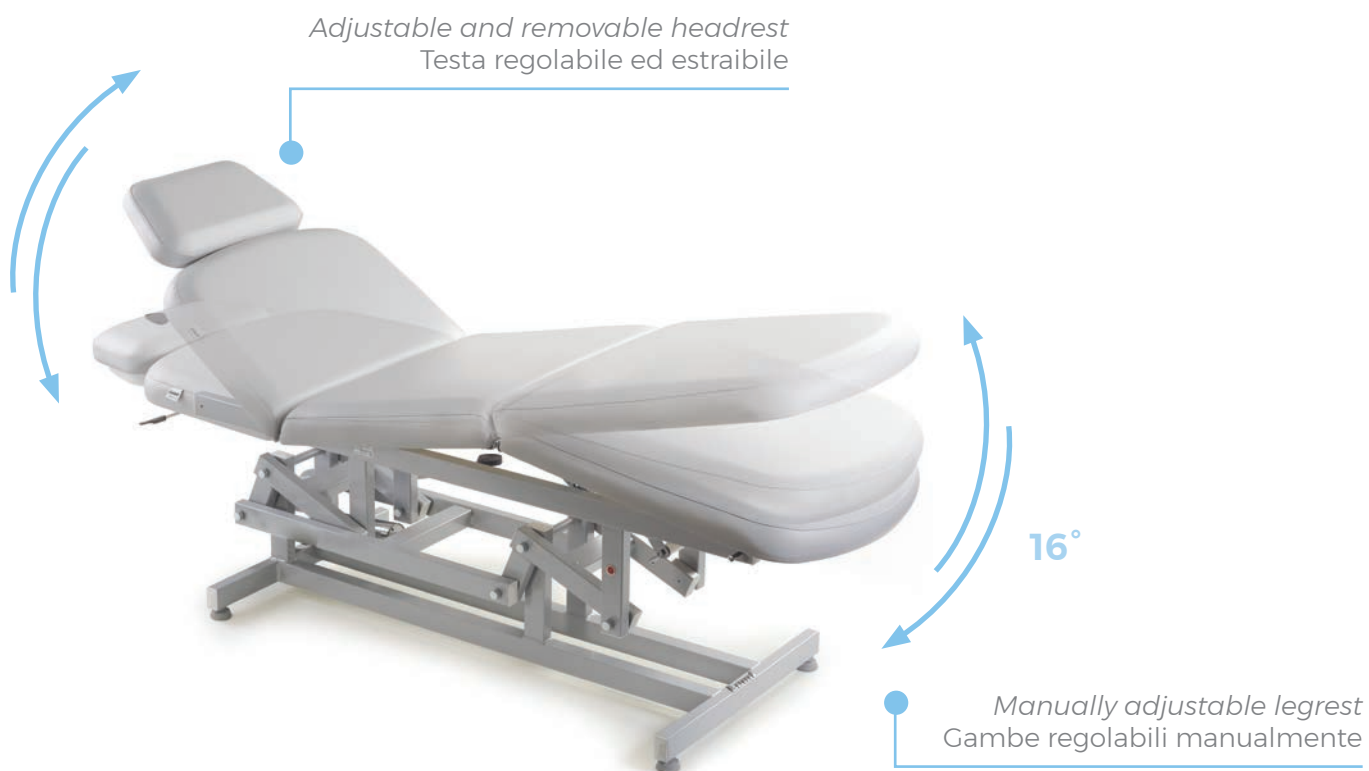

153

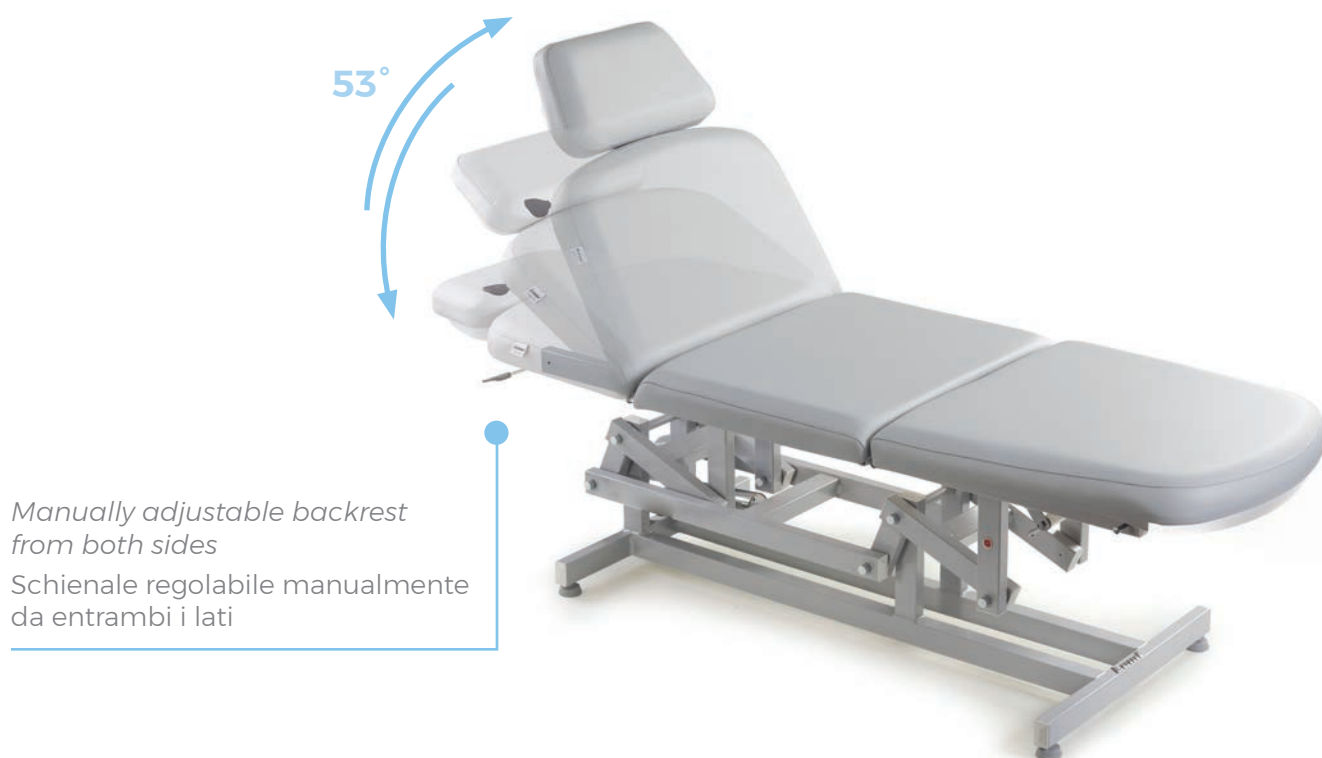



154

* M: Nefos 6

Version with shelf for accessories / Versione con ripiano porta accessori

Focus on

- Stationary treatment table
 - 2 section mattress with face hole
 - Adjustable backrest
 - Shelf for accessories upon request
 - Roll holder included
- Lettino con base fissa
 - Materasso a 2 sezioni con foro viso
 - Schienale regolabile
 - Ripiano porta accessori su richiesta
 - Porta rotolo incluso

On demand

Examples of accessories available upon request at page 163

Esempi di accessori disponibili su richiesta a pagina 163



COD. 002

Stationary table provided with face-hole mattress, roll-holder and a practical shelf for accessories upon request. The seamless flat mattress is easy to clean. Ideal for diagnostics and medical examinations.

Letto ad altezza fissa completo di materasso con foro viso, porta rotolo e un pratico ripiano porta accessori su richiesta. Il materasso piatto senza cuciture è estremamente facile da pulire. Ideale per diagnostica e visite mediche.



Shelf for accessories upon request
Ripiano accessori su richiesta

** The images are for illustrative purposes only and may not reflect the actual image of the finishing.*

** Le immagini hanno valore puramente illustrativo e possono non rispecchiare l'immagine reale della finitura.*

Mattress with face hole / Materasso con foro viso

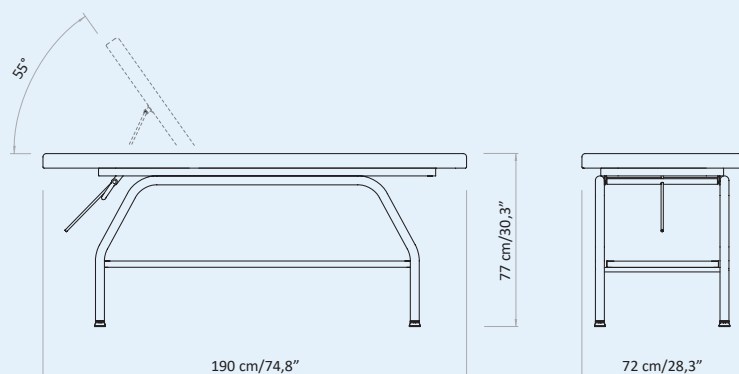

Packaging details

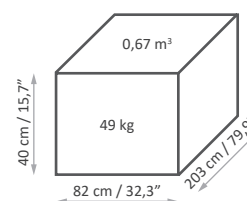

not assembled / smontato



MAXIMUM CAPACITY
PORTATA MASSIMA



150 kg

MOVEMENTS

1 manual movement: backrest



MOVIMENTI

1 movimento manuale: schiena

Two-section seamless mattress
Materasso a due sezioni senza cuciture



Roll-holder
Portarotolo

157

Face-hole mattress
Materasso con foro viso

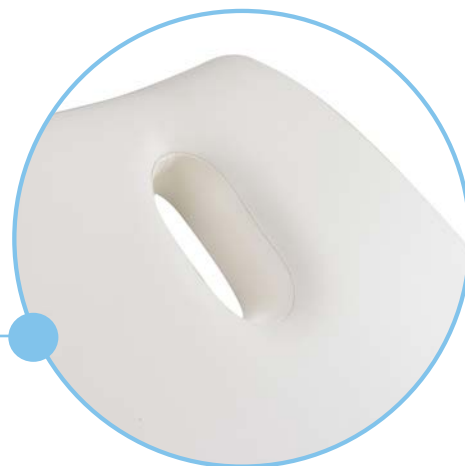

Shelf for accessories (upon request)
Ripiano accessori (su richiesta)



158

* B: Grey | M: Nefos 6985

Standard version / Versione standard

Focus on

- 1 electric motor for height adjustment
 - Adjustable backrest with gas-spring
 - Extremely solid metal base
 - Two-section mattress available with or without face hole
 - Fire retardant class 1IM, "Azo" free, antibacterial, antifungal covering
- 1 motore elettrico per regolazione altezza
 - Schienale regolabile con molla a gas
 - Base metallica estremamente solida
 - Materasso a due sezioni disponibile con o senza foro viso
 - Rivestimento ignifugo classe 1IM, "Azo" free, antibatterico, antimicotico

On demand

Examples of accessories available upon request at page 163

Esempi di accessori disponibili su richiesta a pagina 163

COD. 1142

Somed is a stable and reliable treatment table for general examinations, osteopathy and ultrasounds. Thanks to its adjustable height, Somed ensures maximum ease of access for the patient and at the same time provides optimal working positions for the doctor. The seamless flat mattress is easy to clean.

Somed è un lettino solido ed affidabile ideale per visite generali, osteopatia ed ecografie. Grazie all'altezza regolabile, Somed garantisce la massima facilità di accesso per il paziente e allo stesso tempo assicura una postura di lavoro ottimale per il medico. Il materasso piatto senza cuciture è estremamente facile da pulire.



* M: Nefos 6

Version with face hole
Versione con foro viso



* The images are for illustrative purposes only and may not reflect the actual image of the finishing.

* Le immagini hanno valore puramente illustrativo e possono non rispecchiare l'immagine reale della finitura.

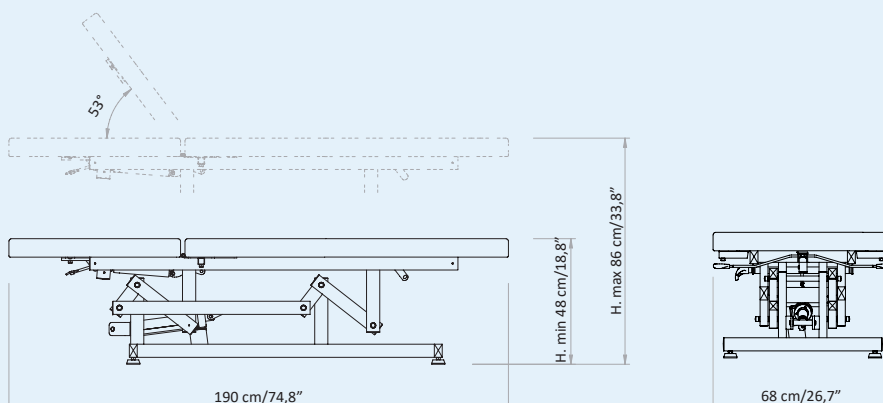

Packaging details

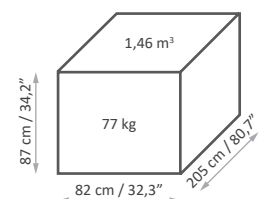

MAXIMUM CAPACITY
PORTATA MASSIMA



150 kg

MOVEMENTS

1 electric movement: height (very low: 48 cm/18,9")

1 manual movement: backrest (with gas spring)

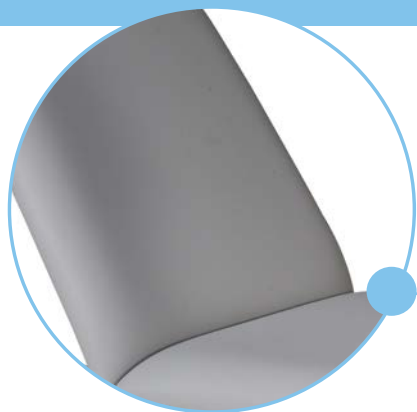

Two-section mattress without stitching
Materasso a due sezioni senza cuciture

Electric height
Altezza elettrica

48-86 cm
(18,9"-33,8")



MOVIMENTI

1 movimento elettrico: altezza (molto bassa: 48 cm)

1 movimento manuale: schiena (con molla a gas)

Manually adjustable backrest from both sides
Schienale regolabile manualmente da entrambi i lati

53°



161

Face hole available upon request
Foro viso disponibile su richiesta

Reduced longitudinal movement during height adjustment
Spostamento longitudinale ridotto durante la salita



LEMI STANDARD

Choose the medical bed with STANDARD CONFIGURATION by LEMI
Scegli il lettino medicale con la CONFIGURAZIONE STANDARD by LEMI

SOMED



1

MATTRESS WITHOUT
FACE HOLE

3

FOOT PEDAL
CONTROL

2

EXTREMELY SOLID
METAL BASE

MATTRESS MATERASSO

Two section mattress with manual backrest
Materasso a due sezioni con schiena manuale

FOOT PEDAL CONTROL PEDALIERA

Practical foot pedal control for bed adjustment
Pratica pedaliera per la regolazione del lettino

EXTREMELY SOLID METAL BASE BASE IN METALLO ESTREMAMENTE SOLIDA

Extremely solid and stable metal base
Base metallica estremamente solida e stabile

ACCESSORIES UPON REQUEST ACCESSORI SU RICHIESTA

Customize the medical bed with the ACCESSORIES available on request.
Personalizza il lettino medicale con gli ACCESSORI disponibili su richiesta.



Mattress with face hole
Materasso con foro viso



Mattress protection with polyurethane
Protezione materasso con poliuretano



Roll Holder (66 cm)
Portarotolo (66 cm)



Wheels with brake (ø 50mm)
Ruote con freno (ø 50mm)



Mattress with customised LOGO
Materasso con LOGO personalizzato

LEMI MATTRESSES

The MATTRESSES of the LEMI MEDICAL line are made with the best quality materials to ensure great stability and maximum hygienisation.



SOSUL

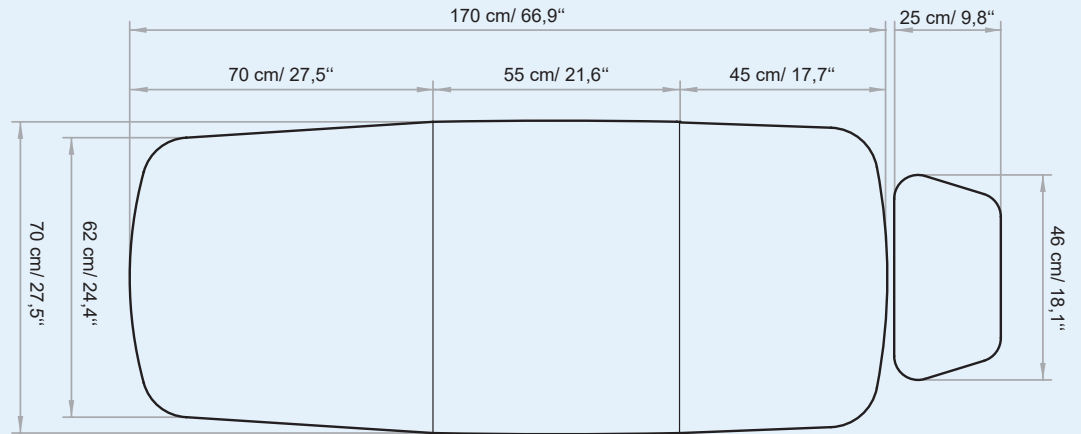

SOMED

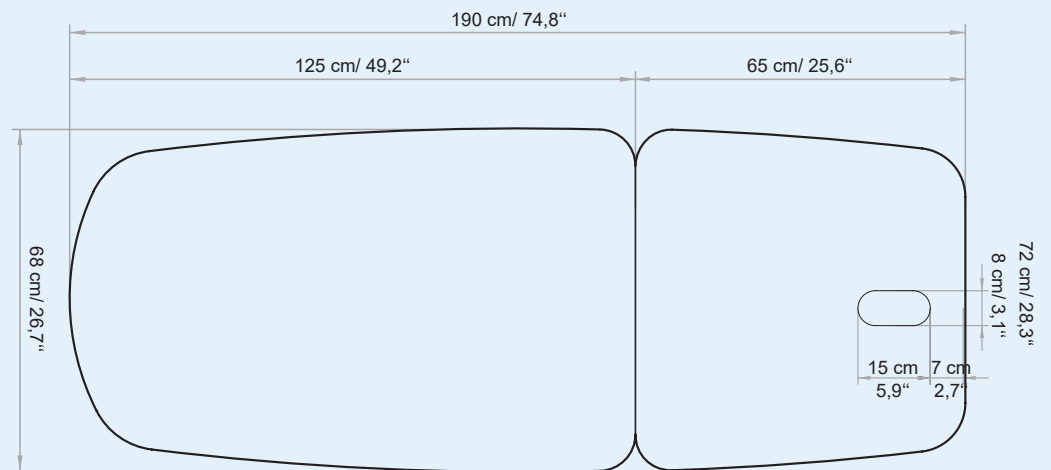

MATERASSI LEMI

I MATERASSI della linea MEDICALE LEMI sono realizzati con materiali della migliore qualità per garantire un'elevata stabilità e la massima igienizzazione.

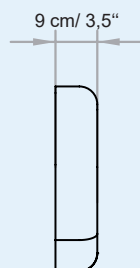
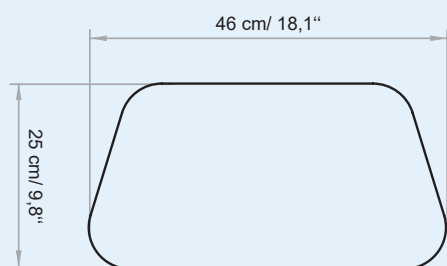

ZAK HEADREST

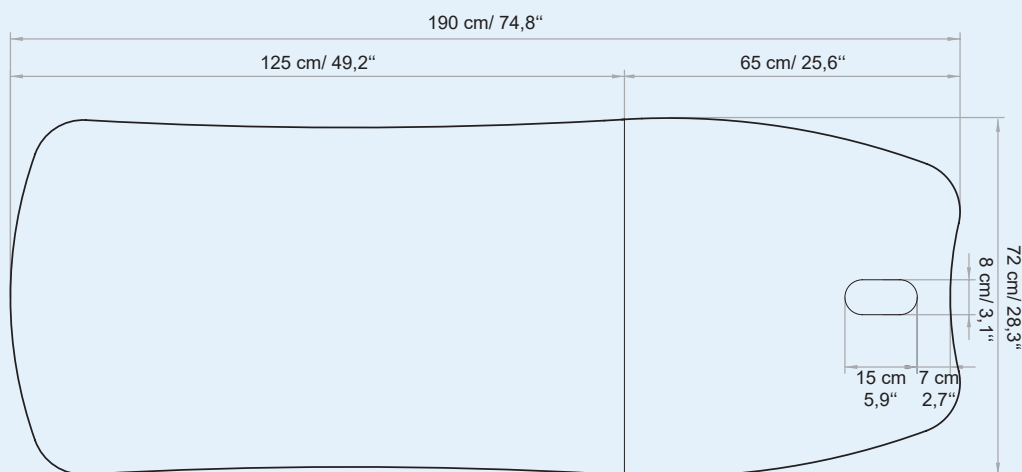
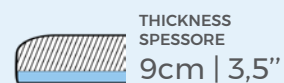

WELL

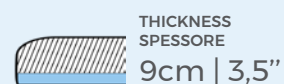



PODIATRY



PODIATRY

Maximum comfort for the patient, optimal ergonomics for the doctor. Lemi PODIATRY CHAIRS are manufactured with utmost attention to detail, offering all the latest technological innovations, while at the same time satisfying even the most strict safety regulations. They have thus come to be recognized as indispensable work tools by doctors worldwide.

Massimo comfort per il paziente, ergonomia ottimale per il medico. Le POLTRONE PODOLOGICHE Lemi sono realizzate con la massima attenzione ai dettagli, offrendo tutte le ultime innovazioni tecnologiche, soddisfacendo allo stesso tempo anche le più severe normative di sicurezza. Sono così divenuti riconosciuti come indispensabili strumenti di lavoro dai professionisti di tutto il mondo.

INDEX
INDICE

PODIATRY

PODO 5	170
PODO HIGH	174
PODO DREAM	178
PODO MIX 3 M	182
PODO MIX 1 - 2 M	186
PODO SLINDER	190



* M: Nefos 1868

Standard version / Versione standard

Stool 070 A

Focus on

- 5 electric motors for height, back, trendelenburg and legs adjustment
- Electrically adjustable legrest and manual extension
- Standard foot pedal control
- Automatic reset function
- Entirely enclosed in ABS covering
- "Easy-to-clean" mattress with flat armrests, zak headrest
- Fire retardant class 1IM, "Azo" free, antibacterial, antifungal covering
- Rotation 180°

- 5 motori elettrici per la regolazione di altezza, schiena, trendelenburg e gambe
- Poggiagambe regolabili elettricamente ed estensione manuale
- Pedaliera standard
- Funzione di azzeramento automatico
- Carter in ABS completamente chiuso
- Materasso "easy to clean" con braccioli automatici, poggiatesta zak
- Rivestimento ignifugo classe 1IM, "Azo" free, antibatterico, antimicotico
- Rotazione 180°

On demand

Examples of accessories available upon request at page 195

Esempi di accessori disponibili su richiesta a pagina 195



COD. 218

Podo 5 is the very first Lemi chair to feature 5 electric motors. Ensuring maximum patient comfort and complete freedom for the doctor. Thanks to its fully electric adjustment, the chair can be easily put horizontal like a bed.

Podo 5 è la prima poltrona Lemi a 5 motori. Progettata per garantire al paziente il massimo comfort e al medico massima libertà di movimento. Grazie alla sua regolazione completamente elettrica, risulta semplice trasformare la poltrona in letto.



Manual leg extension
Estensione gamba manuale

** The images are for illustrative purposes only and may not reflect the actual image of the finishing.*

** Le immagini hanno valore puramente illustrativo e possono non rispecchiare l'immagine reale della finitura.*

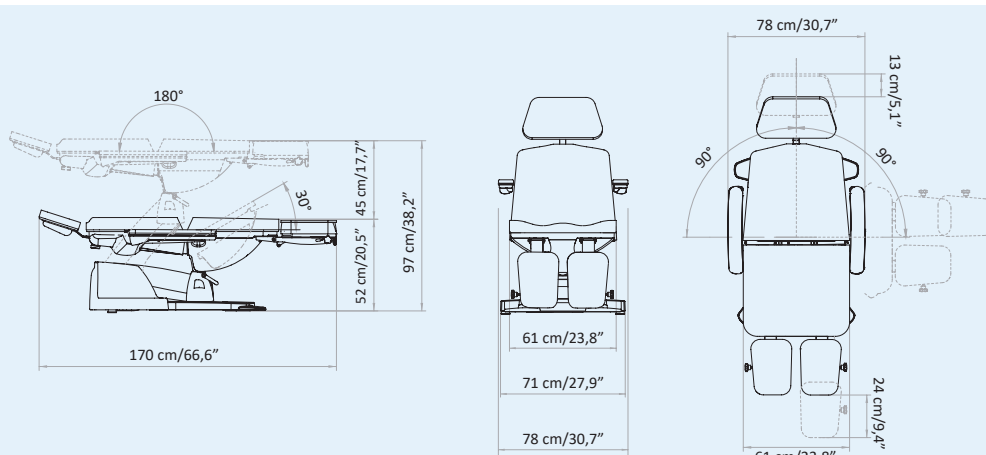

Packaging details

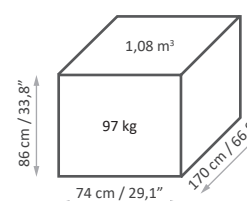

MAXIMUM CAPACITY
PORTATA MASSIMA

200 kg

MOVEMENTS

5 independent electric movements: height, backrest, legrest, trendelenburg

2 manual movements: legrest and headrest extension and inclination

Automatic reset control to bring the chair back to zero position

180° chair rotation

52-97 cm
(20,5"-38,2")

Electric height
Altezza elettrica

Electric Trendelenburg
Trendelenburg elettrico

30°

180°

90° rotation on both sides
Rotazione 90° da entrambi i lati

MOVIMENTI

5 movimenti elettrici indipendenti: altezza, schiena, gambe, trendelenburg

2 movimenti manuali: estensione ed inclinazione di gambe e testa

Comando di azzeramento automatico che riporta il letto nella posizione base

Rotazione poltrona 180°



Adjustable and removable headrest
Testa regolabile ed estraibile



PODO HIGH



174

* M: Nefos 6941

Standard version / Versione standard

Stool 070 A

Focus on

- 3 electric motors for height, back and trendelenburg adjustment
 - Manually adjustable legrest with inclination (90°), extension and rotation
 - Standard foot pedal control
 - Automatic reset function
 - Entirely enclosed in ABS covering
 - "Easy-to-clean" mattress with flat armrests and head pillow
 - Fire retardant class 1IM, "Azo" free, antibacterial, antifungal covering
 - Rotation 180°
- 3 motori elettrici per regolazione di altezza, schiena e trendelenburg
 - Poggiagambe regolabili manualmente con inclinazione 90°, estensione e rotazione
 - Pedaliera standard
 - Funzione di azzeramento automatico
 - Carter in ABS completamente chiuso
 - Materasso "easy to clean" con braccioli automatici e cuscino per la testa
 - Rivestimento ignifugo classe 1IM, "Azo" free, antibatterico, antimicotico
 - Rotazione 180°

On demand

Examples of accessories available upon request at page 195

Esempi di accessori disponibili su richiesta a pagina 195



COD. 204

Podo High is an ergonomic and functional podiatry chair designed to provide maximum comfort for the patient and allow the doctor to change the working position, thanks to the very low min. height of 52 cm and the considerable max. height of 103 cm. Featuring 3 motors with automatic reset function.

Podo High è una poltrona podologica ergonomica e funzionale progettata per garantire il massimo comfort al paziente e consentire al medico di alternare la posizione di lavoro, grazie all'altezza min. di 52 cm e all'altezza max di 103 cm. Dotata di 3 motori elettrici con funzione di ritorno automatico.

Manual leg extension
Estensione gamba manuale

** The images are for illustrative purposes only and may not reflect the actual image of the finishing.*

** Le immagini hanno valore puramente illustrativo e possono non rispecchiare l'immagine reale della finitura.*

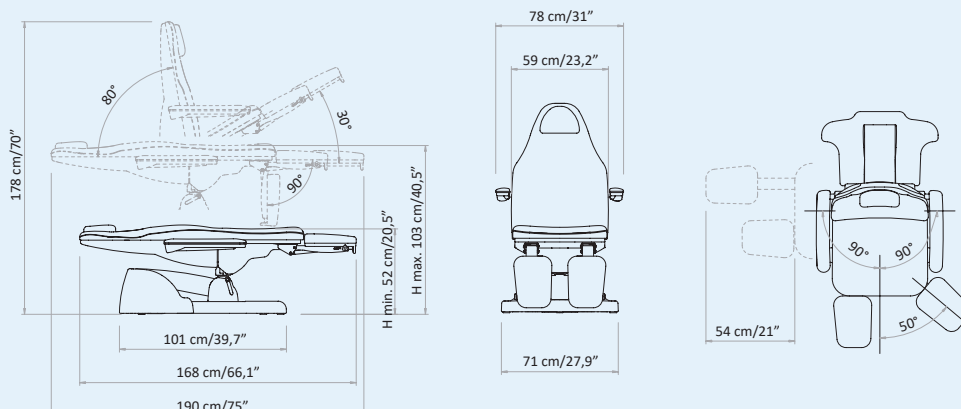

Packaging details

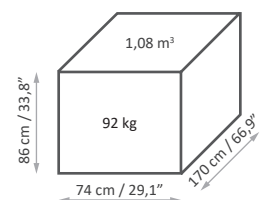

MAXIMUM CAPACITY
PORTATA MASSIMA

200 kg

MOVEMENTS

3 independent electric movements: height, back and trendelenburg
3 manual legrest movements: extension, inclination (90°) and rotation
1 manual movement: head support adjustment
Automatic reset control to bring the chair back to the initial position
180° chair rotation



Head support
Poggiatesta

52-103 cm
(20,5"-40,5")

Electric height
Altezza elettrica



Electric Trendelenburg
Trendelenburg elettrico



30°

Manual legrest rotation and extension
Rotazione ed estensione gambe manuale



50°

MOVIMENTI

3 movimenti elettrici indipendenti: altezza, schiena e trendelenburg

3 movimenti manuali gambe: estensione, inclinazione 90° e rotazione

1 movimento manuale: regolazione poggiatesta

Comando di azzeramento automatico che riporta la poltrona nella posizione base

Rotazione poltrona 180°



PODO DREAM



* M: Nefos 5946

Standard version / Versione standard

Stool 070 A

Focus on

- 3 electric motors for height, back and trendelenburg adjustment
 - Manually adjustable legrest with inclination (90°), extension and rotation
 - Standard foot pedal control
 - Automatic reset function
 - Entirely enclosed in ABS covering
 - "Easy-to-clean" mattress with flat armrests and head pillow
 - Fire retardant class 1IM, "Azo" free, antibacterial, antifungal covering
 - Rotation 180°
- 3 motori elettrici per regolazione di altezza, schiena e trendelenburg
 - Poggiagambe regolabili manualmente con inclinazione 90°, estensione e rotazione
 - Pedaliera standard
 - Funzione di azzeramento automatico
 - Carter in ABS completamente chiuso
 - Materasso "easy to clean" con braccioli automatici e cuscino per la testa
 - Rivestimento ignifugo classe 1IM, "Azo" free, antibatterico, antimicotico
 - Rotazione 180°

On demand

Examples of accessories available upon request at page 195

Esempi di accessori disponibili su richiesta a pagina 195

PODO DREAM

COD. 205

Podo Dream is an ergonomic and functional podiatry chair designed to provide maximum comfort for the patient and allow the doctor to change the working position, thanks to the very low min. height of 52 cm and the considerable max. height of 82 cm. Featuring 3 motors with automatic reset function.

Podo Dream è una poltrona podologica ergonomica e funzionale progettata per garantire il massimo comfort al paziente e consentire al medico di alternare la posizione di lavoro, grazie all'altezza min. di 52 cm e all'altezza max di 82 cm. Dotata di 3 motori elettrici con funzione di ritorno automatico.



Manual leg extension
Estensione gamba manuale

** The images are for illustrative purposes only and may not reflect the actual image of the finishing.*

** Le immagini hanno valore puramente illustrativo e possono non rispecchiare l'immagine reale della finitura.*

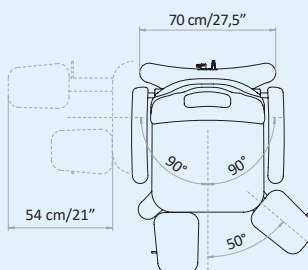
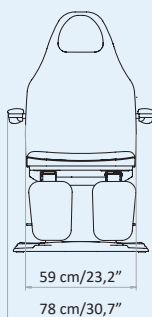
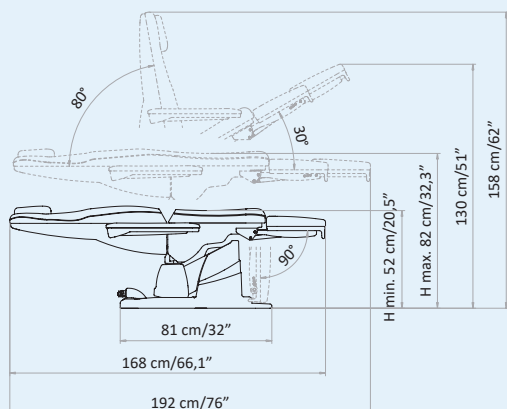

Packaging details

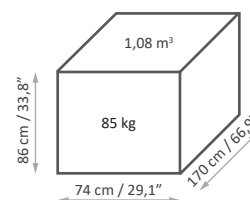

MAXIMUM CAPACITY
PORTATA MASSIMA

200 kg

MOVEMENTS

3 independent electric movements: height, back and trendelenburg
3 manual legrest movements: extension, inclination (90°) and rotation
1 manual movement: head support adjustment
Automatic reset control to bring the chair back to the initial position
180° chair rotation



Head support
Poggiatesta

52-82 cm
(20,5"-32,3")

Electric height
Altezza elettrica



Electric Trendelenburg
Trendelenburg elettrico

30°



90° rotation on both sides
Rotazione 90° da entrambi i lati

180°



MOVIMENTI

3 movimenti elettrici indipendenti: altezza, schiena e trendelenburg

3 movimenti manuali gambe: estensione, inclinazione 90° e rotazione

1 movimento manuale: regolazione poggiatesta

Comando di azzeramento automatico che riporta la poltrona nella posizione base

Rotazione poltrona 180°



Adjustable and removable legrest
Gambe regolabili ed estraibili



PODO MIX 3M



182

* M: Nefos 6

Standard version / Versione standard

Focus on

- 3 electric motors for height, back and tilting adjustment
- Manually adjustable legrests with inclination (90°), extension and rotation
- Standard pedal control with 2 options for MEMORY function
- AUT function: "End of treatment" position **NEW**
- END function: automatic return from any position to zero position (flat and minimum height) **NEW**
- Entirely enclosed in ABS covering
- "Easy-to-clean" mattress
- Fire retardant class 1IM, "Azo" free, antibacterial, antifungal covering
- Standard mattress with flat armrests and Zak headrest
- Rotation 180°

On demand

Examples of accessories available upon request at page 195

- 3 motori elettrici per regolazione di altezza, schiena e basculante
- Poggiagambe regolabili manualmente con inclinazione 90°, estensione e rotazione
- Pedaliera standard con 2 opzioni di funzione MEMORIE
- Funzione AUT: posizione "fine del trattamento" **NEW**
- Funzione END: ritorno automatico da ogni posizione alla posizione zero (piatto e altezza minima) **NEW**
- Carter in ABS completamente chiuso
- Materasso "easy to clean"
- Rivestimento ignifugo classe 1IM, "Azo" free, antibatterico, antimicotico
- Materasso standard con braccioli automatici e testa Zak
- Rotazione 180°

Esempi di accessori disponibili su richiesta a pagina 195

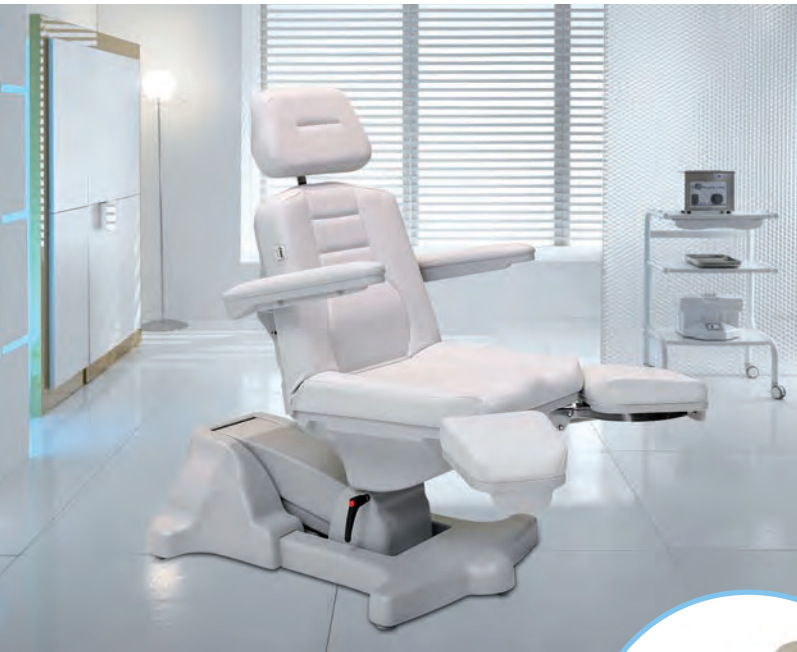

COD. 852

Podo Mix 3M is designed to provide maximum comfort for the client and to allow the practitioner to change the working position. The Podo Mix 3M base starts from a very low min. height to a considerable max. height. It ensures ease of use and functionality. The mattress features an adjustable Zak headrest and a comfortable backrest when completely flat.

Podo Mix 3M è progettato per offrire il massimo comfort per il cliente e consentire allo specialista di cambiare la posizione di lavoro. Infatti, la base di Podo Mix parte da un'altezza minima molto bassa, fino ad arrivare a una considerevole altezza massima. Garantisce facilità d'uso e funzionalità. Il materasso è dotato di poggiatesta Zak regolabile e schienale confortevole quando completamente piatto.



Manual leg extension
Estensione gamba manuale

** The images are for illustrative purposes only and may not reflect the actual image of the finishing.*

** Le immagini hanno valore puramente illustrativo e possono non rispecchiare l'immagine reale della finitura.*

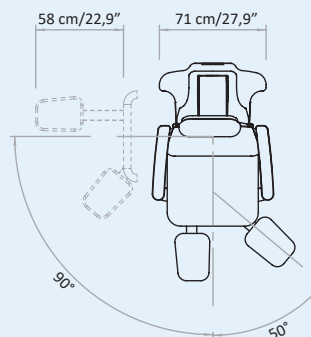
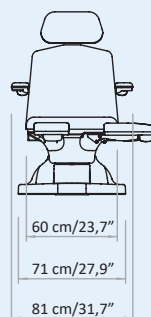
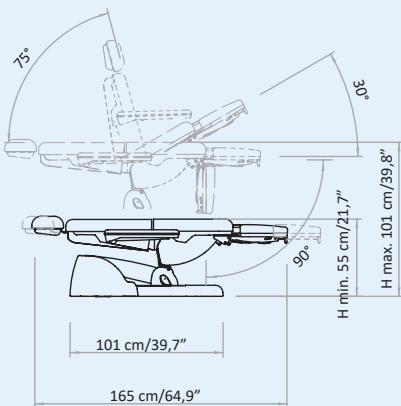

Packaging details

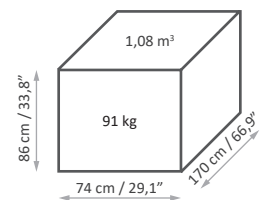

MAXIMUM CAPACITY
PORTATA MASSIMA

200 kg

MOVEMENTS

3 independent electric movements: height, back and trendelenburg

3 manual legrest movements: extension, inclination (90°) and rotation

AUT: automatic reset control to bring the chair back to the initial position

END: automatic return from any position to zero position (flat and minimum height)

Standard pedal control with 2 options for MEMORY function

Chair rotation 180°

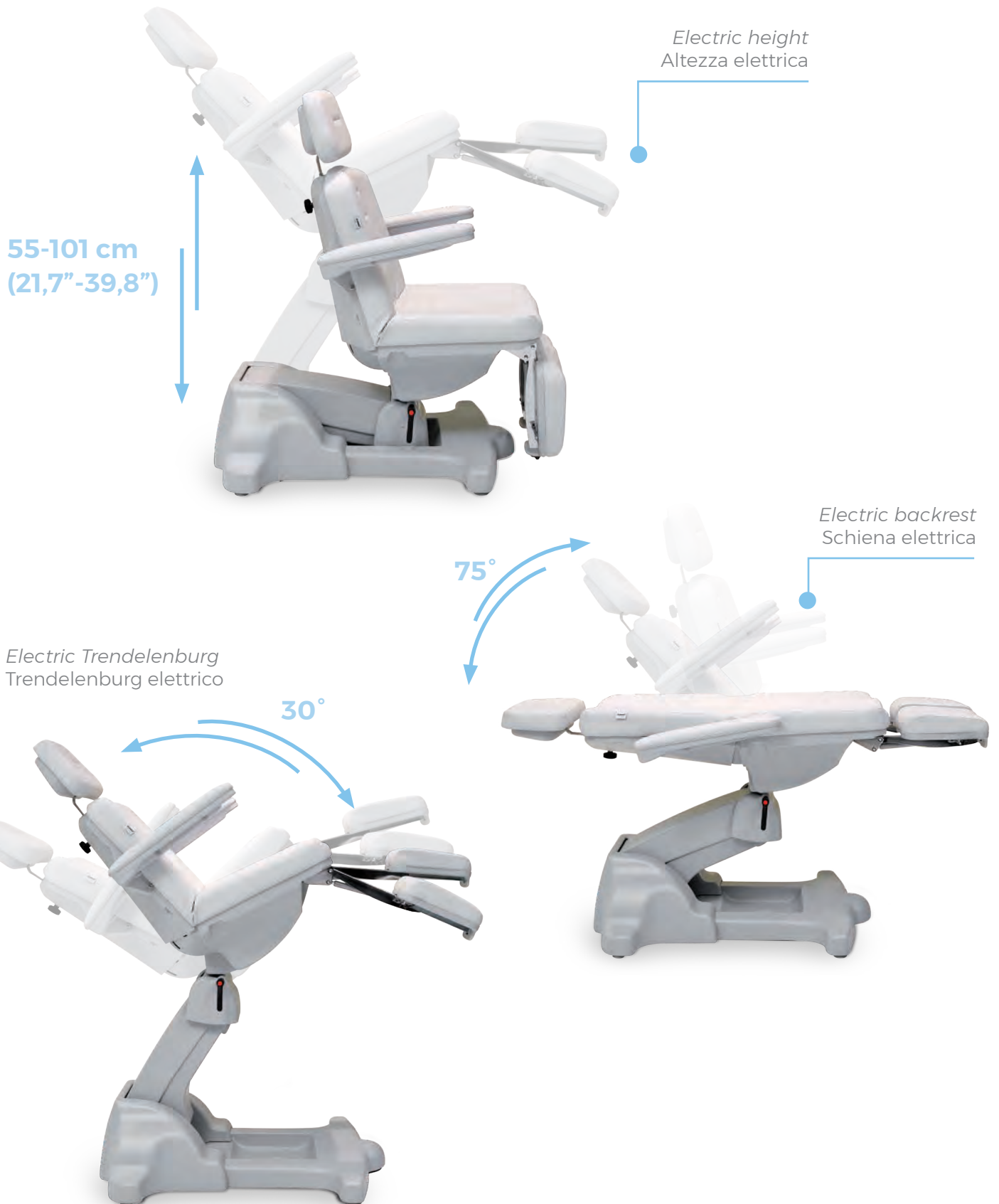

MOVIMENTI

3 movimenti elettrici indipendenti: altezza, schiena e trendelenburg

3 movimenti manuali gambe: estensione, inclinazione 90° e rotazione

AUT: comando di azzeramento automatico che riporta la poltrona nella posizione base

END: ritorno automatico da ogni posizione alla posizione zero (piatto e altezza minima)

Pedaliera standard con 2 opzioni di funzione MEMORIE

Rotazione poltrona 180°

90° rotation on both sides
Rotazione 90° da entrambi i lati



Manual headrest and legrest
Testa e gambe manuali



Adjustable and removable headrest
Testa regolabile ed estraibile



Manual legrest
Gambe manuali



PODO MIX 1-2M



186

* M: Nefos 3962

Standard version / Versione standard

Stool 070 A

Focus on

- Version with 2 electric motors for height and trendelenburg adjustment
- Version with 1 electric motor for height adjustment
- Manually adjustable legrest with inclination and extension
- Standard foot pedal control
- AUT function: "End of treatment" position (only Podo Mix 2M)
- Entirely enclosed in ABS covering
- "Easy-to-clean" mattress with flat armrests, zak headrest and two pieces legs
- Fire retardant class 1IM, "Azo" free, antibacterial, antifungal covering
- Rotation 180°

- Versione con 2 motori elettrici per regolazione altezza e trendelenburg
- Versione con 1 motore elettrico per regolazione altezza
- Poggiagambe regolabile manualmente con inclinazione ed estensione
- Pedaliera standard con funzione
- Funzione AUT: posizione "fine del trattamento" (Solo Podo Mix 2M)
- Carter in ABS completamente chiuso
- Materasso "easy to clean" con braccioli automatici, testa zak e gambe separate in due parti
- Rivestimento ignifugo classe 1IM, "Azo" free, antibatterico, antimicotico
- Rotazione 180°

On demand

Examples of accessories available upon request at page 195

Esempi di accessori disponibili su richiesta a pagina 195

PODO MIX 1-2M

UPGRADE



COD. 1169 1M
COD. 1168 2M

Podo Mix 1-2M is an ergonomic and functional podiatry chair designed to provide maximum comfort for the patient and allow the doctor to change the working position, thanks to the very low min. height of 55 cm and the considerable max. height of 101 cm. Mattress with Zak headrest and comfortable back when completely flat like a bed.

Podo Mix 1-2M è una poltrona podologica ergonomica e funzionale progettata per garantire il massimo comfort al client e consentire al medico di alternare la posizione di lavoro, grazie all'altezza min. di 55 cm e all'altezza max di 101 cm. Dotata di materasso con testa Zak e schienale confortevole in posizione orizzontale da lettino.

187

** The images are for illustrative purposes only and may not reflect the actual image of the finishing.*

** Le immagini hanno valore puramente illustrativo e possono non rispecchiare l'immagine reale della finitura.*

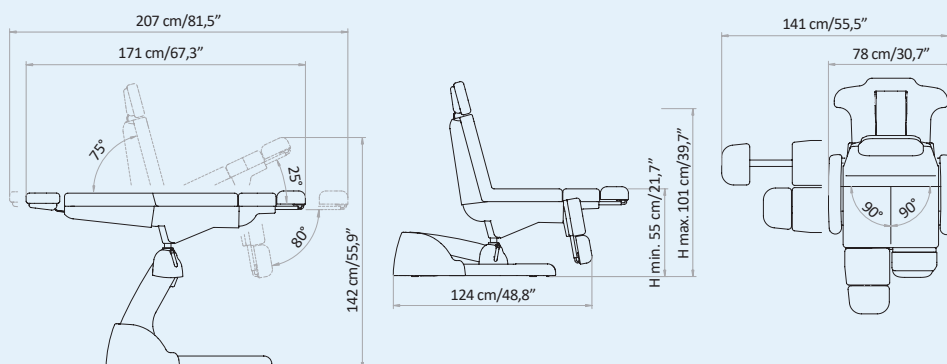

Packaging details

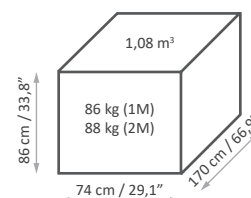

MAXIMUM CAPACITY
PORTATA MASSIMA



200 kg

MOVEMENTS - PODO MIX 1 - 2M

2 independent electric movements: height (1M) and trendelenburg (2M)

4 manual movement: backrest, legrest extension/inclination, headrest adjustment

Automatic reset control to bring the chair back to zero position (2M)

180° chair rotation

**56-101 cm
(22" - 39,8")**



*Electric height
Altezza elettrica*

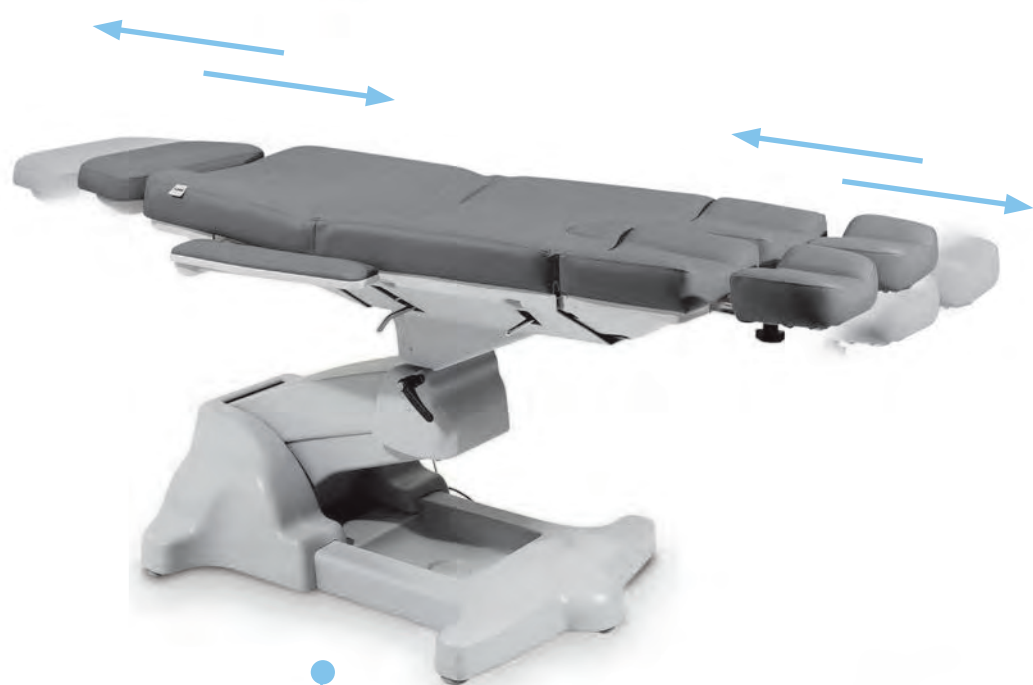

*Manual headrest and legrest
Testa e gambe manuali*

MOVIMENTI - PODO MIX 1 - 2M

2 movimenti elettrici indipendenti: altezza (1M) e trendelenburg (2M)

4 movimenti manuali: schienale, estensione/inclinazione gambe, regolazione testa

Comando di azzeramento automatico che riporta il letto nella posizione base (2M)

Rotazione poltrona 180°

Electric trendelenburg
Trendelenburg elettrico



Adjustable and removable headrest
Testa regolabile ed estraibile

189



90° rotation on both sides
Rotazione 90° da entrambi i lati

PODO SLINDER



* M: Nefos 667

Standard version / Versione standard

Stool 070 A

Focus on

- 2 electric motors for height and trendelenburg adjustment
 - Manually adjustable legrest with inclination, extension and 90° rotation
 - Backrest Manually reclining (it does not allow completely flat position)
 - Standard foot pedal control
 - Automatic reset function
 - Bi-color "Easy-to-clean" mattress without stitching
 - Fire retardant class 1IM, "Azo" free, antibacterial, antifungal covering
 - Rotation 180°
- 2 motori elettrici per regolazione altezza e trendelenburg
 - Poggiatesta regolabili manualmente con inclinazione, estensione e rotazione di 90°
 - Schienale reclinabile manualmente (non consente la posizione completamente orizzontale)
 - Pedaliera standard
 - Funzione di azzeramento automatico
 - Materasso "easy to clean" senza cuciture bi-colore
 - Rivestimento ignifugo classe 1IM, "Azo" free, antibatterico, antimicotico
 - Rotazione 180°

On demand

Examples of accessories available upon request at page 195

Esempi di accessori disponibili su richiesta a pagina 195

PODO SLINDER

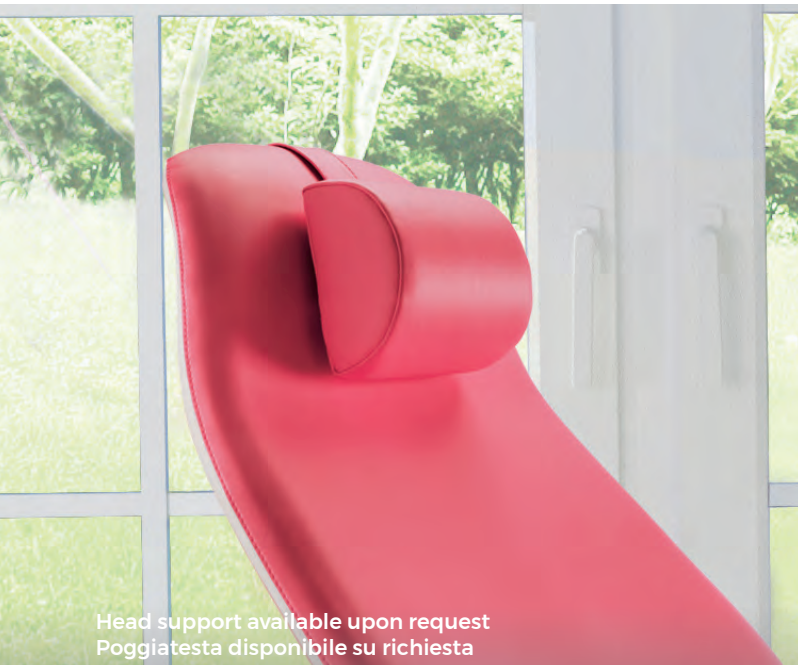

COD. 214

Podo Slinder is Lemi podiatry chair featuring an ergonomic thin mattress and BAT armrests. Podo Slinder min. height of 47 cm allows patient's easy access while, thanks to different adjustments, the doctor can change the working position. Fully upholstered mattress, standard two-tone with gray back. Ensuring ergonomics and comfort.

Podo Slinder è la poltrona podologica Lemi dotata di un materasso sottile ergonomico e completa di braccioli BAT. L'altezza minima di Podo Slinder di 47 cm permette al paziente di accomodarsi facilmente, allo stesso tempo il medico può cambiare la posizione di lavoro. Materasso completamente rivestito, bicolore standard con retro grigio. Assicura ergonomia e confort.

** The images are for illustrative purposes only and may not reflect the actual image of the finishing.*

** Le immagini hanno valore puramente illustrativo e possono non rispecchiare l'immagine reale della finitura.*

Head support available upon request
Poggiatesta disponibile su richiesta

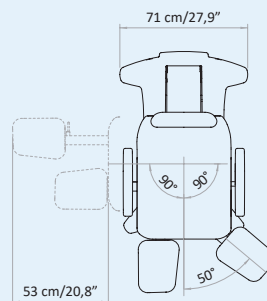
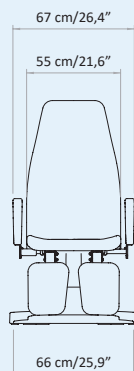
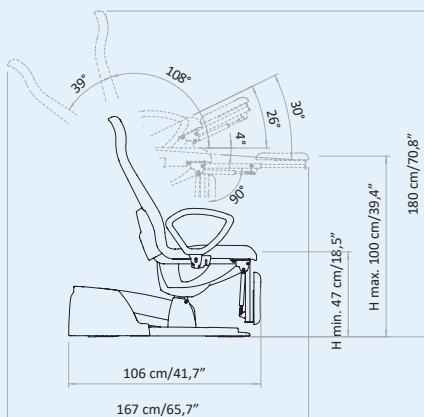

Packaging details

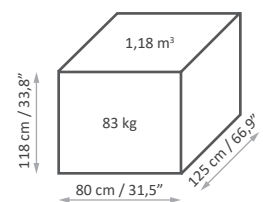

MAXIMUM CAPACITY
PORTATA MASSIMA



200 kg

MOVEMENTS

2 independent electric movements: height and trendelenburg

Manual backrest reclining

3 manual legrest movements: extension, inclination (90°) and rotation

Automatic reset control to bring the chair back to zero position

180° chair rotation

47-100 cm
(18,5"-39,4")

Electric height
Altezza elettrica



30°

Electric Trendelenburg
Trendelenburg elettrico



180°

90° rotation on both sides
Rotazione 90° da entrambi i lati



MOVIMENTI

2 movimenti elettrici indipendenti: altezza e trendelenburg

Schienale reclinabile manualmente

3 movimenti manuali gambe: estensione, inclinazione 90° e rotazione

Comando di azzeramento automatico che riporta il letto nella posizione base

Rotazione poltrona 180°



LEMI STANDARD

Choose the podiatry chair with STANDARD CONFIGURATION by LEMI

Scegli la poltrona podologica con la CONFIGURAZIONE STANDARD by LEMI

PODDO DREAM

4
FLAT
ARMRESTS

3
FOOT PEDAL
CONTROL

1
HEAD
SUPPORT

2
MANUAL
LEGREST



HEAD SUPPORT POGGIATESTA

Comfortable and adjustable headrest
Comodo poggiatesta regolabile

MANUAL LEGREST GAMBA MANUALE

Manual adjustment of leg extension
Regolazione manuale estensione della gamba

FOOTREST PEDALIERA

Practical foot pedal control for chair adjustment
Pratica pedaliera per regolazione poltrona

FLAT ARMREST BRACCIOLI AUTOMATICI

Couple of flat armrests following the bed flat position
Coppia di braccioli automatici che si allineano alla posizione piatta del lettino

ACCESSORIES UPON REQUEST ACCESSORI SU RICHIESTA

Customize the podiatry chair with the ACCESSORIES available on request.
Personalizza la poltrona podologica con gli ACCESSORI disponibili su richiesta.

LEGS GAMBE



Option for splitted automatic legrest
Opzione per gambe automatiche divise



Cushion between seat and legrest
Cuscino fra seduta e gamba



Legrest covering
Proteggi gambe in tessuto



Plastic leg protection
Protezione gambe in plastica



Roll Holder (66 cm)
Portarotolo (66 cm)



Wheels with brake (ø 50mm)
Ruote con freno (ø 50mm)



Wireless foot pedal control
Pedaliera wireless



Handset control
Pulsantiera



Customization with logo
Personalizzazione con logo

LEMI MATTRESSES

The MATTRESSES of LEMI *PODOLOGICAL* line are made with the best quality materials to ensure maximum comfort for both the patient and the doctor.



PODO DREAM
PODO HIGH

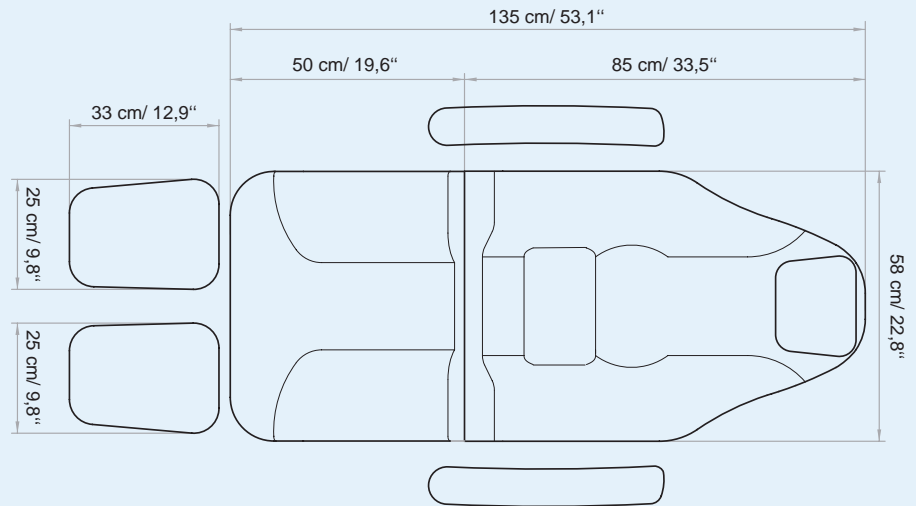

PODO 5
PODO MIX 3M

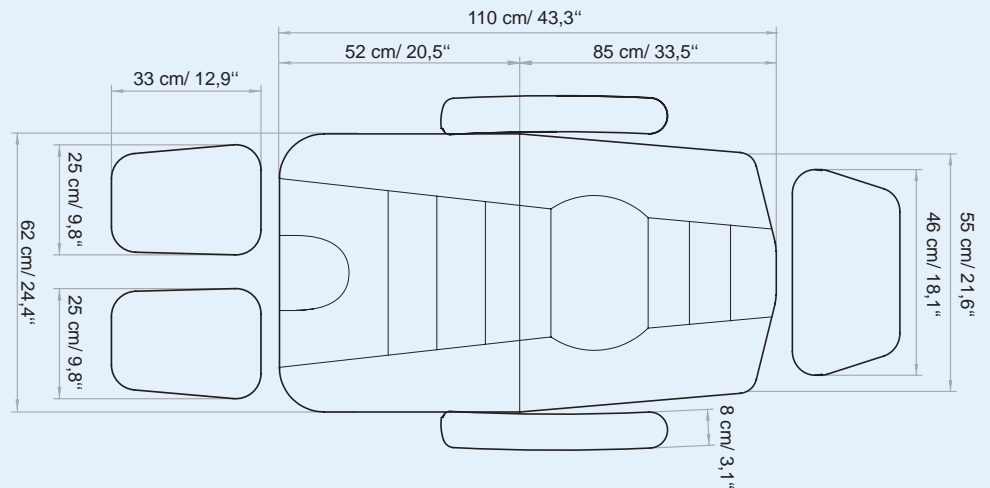

PODO SLINDER

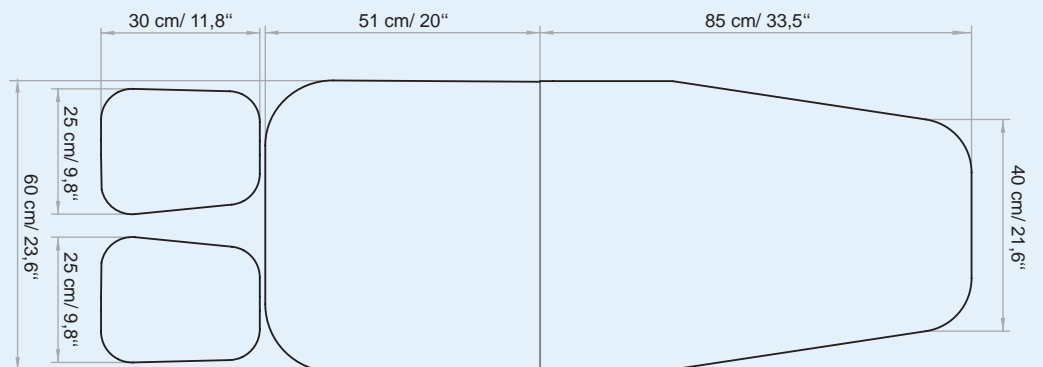

MATERASSI LEMI

I MATERASSI della linea **PODOLOGICA LEMI** sono realizzati con materiali della migliore qualità per garantire il massimo comfort sia per il paziente che per il medico.

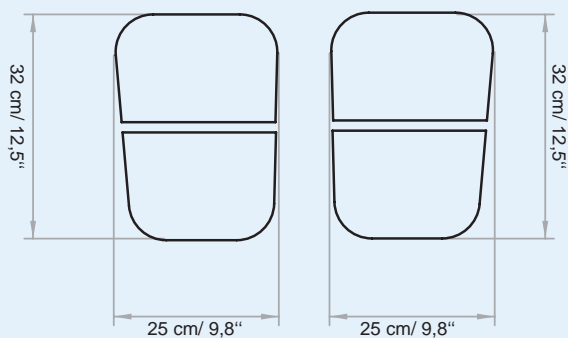

SPLITTED LEGREST
UPON REQUEST FOR PODO DREAM, HIGH, MIX 3M, 5
SU RICHIESTA PER PODO DREAM, HIGH, MIX 3M, 5

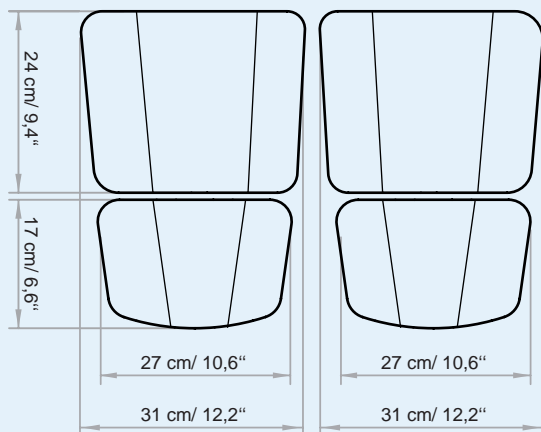

SPLITTED LEGREST
STANDARD FOR PODO MIX 1-2 M
STANDARD PER PODO MIX 1-2 M

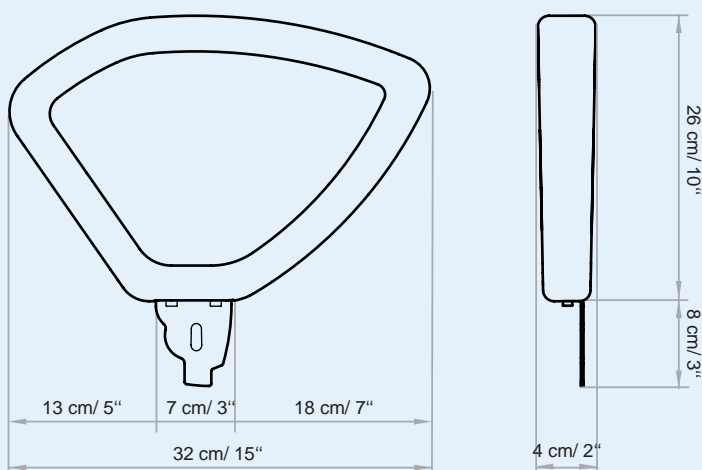
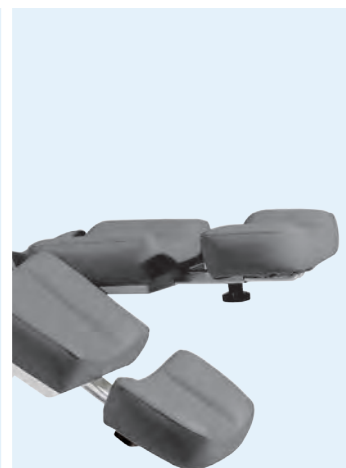

BAT ARMREST



MATTRESS CUSTOMIZATION

PERSONALIZZAZIONE MATERASSO

*The innovative **Nefos** materials - which are exclusive for LEMI products - and their special finishing touch guarantee easy-cleaning and hygiene. Their extraordinary structural qualities will persist through the years. An incredibly elastic texture enhances the memory foam mattress softness and quality at its best.*

Gli innovativi materiali **Nefos** - che sono un'esclusiva dei prodotti LEMI - ed il loro speciale tocco di finitura garantiscono una facile pulizia e igiene. Le loro straordinarie qualità strutturali permangono nel corso degli anni. Una texture incredibilmente elastica migliora al massimo la morbidezza e la qualità del materasso in Memory Foam.



BASE FEATURES

CARATTERISTICHE BASE

We provide a thermoformed ABS base, completely closed to prevent any infiltration of powders or liquids. It is a very strong material, scratch-proof resistant and easy-to-clean.

Forniamo una base in ABS termoformato, completamente chiuso per evitare qualsiasi infiltrazione di polveri o liquidi. È un materiale molto robusto, resistente ai graffi e facile da pulire.

The images are for illustrative purposes only and may not reflect the actual finish of the product, particularly when viewed through a screen. Therefore, the **SELECTION OF THE MATTRESS FABRICS** must take place **AFTER CONSULTING** the **PHYSICAL SAMPLES** of the **NEFOS COLOR CHART**.

ANTIMICROBIAL TECHNOLOGY

TECNOLOGIA ANTIMICROBICA



WHAT DOES IT MEAN?

CHE COSA SIGNIFICA?

The Nefos vinyl leather fabric is made through production processes involving an antimicrobial additive technology. Studies show that fabrics treated with this technology are up to 99.9% resistant to harmful bacteria.

The exceptional result that derives from it is a sanitized fabric with a permanent effect, whose matrix guarantees safety from any contamination thanks to the antibacterial, antifungal and anti-mold effect, which protects the coating from fungal attacks that can cause damage or bad smells, for the entire product's life cycle. The antimicrobial additive technology protects the fibers without changing their characteristics, thus preserving their freshness over time.

A high level of hygiene is essential, that's why this kind of technology was chosen by LEMI for all its bed and chair lines. The peculiarity of these coatings has allowed LEMI to give further value to its products, since thanks to this technology, the cleaning phase of Nefos vinyl leather fabric does not require the use of sanitizing products but requires the use of a soft cloth moistened and soapy, to be rinsed simply with clean water.

La linea di rivestimenti in vinilpelle Nefos è realizzata attraverso processi produttivi che coinvolgono una tecnologia additivante antimicrobica. Studi dimostrano che i tessuti trattati con questa tecnologia sono resistenti fino al 99,9% ai batteri nocivi.

Il risultato eccezionale che ne deriva è un tessuto igienizzato ad effetto permanente, la cui matrice garantisce sicurezza da eventuali contaminazioni grazie all'effetto antibatterico, antifungino e antimuffa, il quale protegge il rivestimento da attacchi micotici che possono essere causa di danni o di cattivi odori, per l'intera durata del ciclo di vita del prodotto. La tecnologia additivante antimicrobica protegge le fibre senza modificarne le caratteristiche, conservandone così la freschezza nel tempo.

Un alto livello di igiene è fondamentale, ecco perché questo tipo di tecnologia è stata scelta da LEMI per tutte le sue linee di poltrone e lettini. La peculiarità di questi rivestimenti ha permesso a LEMI di dare un ulteriore pregio ai propri prodotti, poiché proprio grazie a questa tecnologia, la fase di pulizia dei tessuti vinilpelle Nefos non necessita dell'utilizzo di prodotti igienizzanti ma prevede l'uso di un panno morbido inumidito e insaponato, da sciacquare semplicemente con acqua pulita.

Le immagini hanno valore puramente illustrativo e possono non rispecchiare la finitura reale del prodotto, in particolare se visualizzate attraverso uno schermo. Pertanto la **SELEZIONE DEI RIVESTIMENTI DEI MATERASSI** deve avvenire **PREVIA CONSULTAZIONE** della **CAMPIONATURA FISICA** della **CARTELLA COLORI NEFOS**.

TECHNICAL REQUIREMENTS

CARATTERISTICHE TECNICHE

	<i>voltage</i> voltaggio	<i>frequency</i> frequenza	<i>absorption</i> assorbimento	<i>transformer</i> trasformatore	<i>protection rating</i> grado di protezione	<i>electric system conforms to CEI norms</i> impianto elettrico a norme CEI	<i>control box</i> centralina
200 <i>electric requirements</i> caratteristiche elettriche	230/110V ac	50/60 Hz	0,7 - 1 A max	120 Va	IP 54	4	<i>class II</i> classe II
<i>electric requirements</i> caratteristiche elettriche	240/100V ac	50/60 Hz	2,5 Amp max	-	IP 54	60601-1	<i>class II</i> classe II

WARRANTY

structure: 10 years

motors and controls: 2 years

undeformable foam: 5 years

GARANZIA

struttura: 10 anni

motori e comandi: 2 anni

gomma indeformabile: 5 anni

REGULATIONS

All Equipment is  marked

Electrical equipment and beds

Directive 2006/42/CE (Machinery Directive) and national regulations

Directive 2014/30/UE (Electromagnetic Compatibility Directive) and national regulations

Medical devices

Directive 93/42/CEE (Medical Devices Directive) and D. Lgs 24th February 1997,

n. 46 - medical device Class I (rule 12) annexe IX dir. 93/42/CEE

Images

The images are for illustrative purposes only and may not reflect the actual image of the product.

NORME

Tutte le attrezzature sono a marchio 

Attrezzature e lettini elettrici

Direttiva 2006/42/CE (Direttiva Macchine) e disposizioni nazionali di attuazione

Direttiva 2014/30/UE (Direttiva Compatibilità elettromagnetica) e disposizioni nazionali di attuazione

Dispositivi medici

Direttiva 93/42/CEE concernente i dispositivi medici e D. Lgs 24 Febbraio 1997,

n.46 - dispositivo medico di classe I (regola 12) secondo l'allegato IX dir.93/42/CEE

Immagini

Le immagini hanno valore puramente illustrativo e possono non rispecchiare l'immagine reale del prodotto.



SGABELLI



STOOLS

Lemi offers a wide range of stools to be matched with medical and podiatry chairs. All stools are made from the highest quality materials and designed to ensure maximum functionality.

Lemi propone una linea completa di sgabelli coordinabili con le poltrone medicali e podologiche. Tutti gli sgabelli sono caratterizzati da finiture e materiali di altissima qualità e sono progettati per garantire la massima funzionalità.

STOOLS

STOOLS

The *STOOLS* line is complete with a wide range of seats available with gas lift or hydraulic lift, with or without backrest.



030/S

Height min 46 cm 18,1"
Height max 60 cm 23,6"

Altezza min 46 cm 18,1"
Altezza max 60 cm 23,6"



030

Height min 46 cm 18,1"
Height max 60 cm 23,6"

Altezza min 46 cm 18,1"
Altezza max 60 cm 23,6"



050/S

Height min 46 cm 18,1"
Height max 60 cm 23,6"

Altezza min 46 cm 18,1"
Altezza max 60 cm 23,6"



050

Height min 46 cm 18,1"
Height max 60 cm 23,6"

Altezza min 46 cm 18,1"
Altezza max 60 cm 23,6"

030/S PEDI

Height min 44 cm 17,3"
Height max 54 cm 21,2"

Altezza min 44 cm 17,3"
Altezza max 54 cm 21,2"

030 PEDI

Height min 44 cm 17,3"
Height max 54 cm 21,2"

Altezza min 44 cm 17,3"
Altezza max 54 cm 21,2"

050/S PEDI

Height min 44 cm 17,3"
Height max 54 cm 21,2"

Altezza min 44 cm 17,3"
Altezza max 54 cm 21,2"

050 PEDI

Height min 44 cm 17,3"
Height max 54 cm 21,2"

Altezza min 44 cm 17,3"
Altezza max 54 cm 21,2"



052/S - 052

Height min 57 cm 22,4"
Height max 75 cm 29,5"

Altezza min 57 cm 22,4"
Altezza max 75 cm 29,5"



015

Height min 46 cm 18,1"
Height max 60 cm 23,6"

Altezza min 46 cm 18,1"
Altezza max 60 cm 23,6"



019

Height min 46 cm 18,1"
Height max 60 cm 23,6"

Altezza min 46 cm 18,1"
Altezza max 60 cm 23,6"



070A

Height min 43 cm 16,9"
Height max 57 cm 22,4"

Altezza min 43 cm 16,9"
Altezza max 57 cm 22,4"

015 PEDI

Height min 44 cm 17,3"
Height max 54 cm 21,2"

Altezza min 44 cm 17,3"
Altezza max 54 cm 21,2"

019 PEDI

Height min 44 cm 17,3"
Height max 54 cm 21,2"

Altezza min 44 cm 17,3"
Altezza max 54 cm 21,2"

SGABELLI

La linea *STOOLS* è completa di una vasta gamma di sedute disponibili con pompa a gas o idraulica, con o senza schienale.



021/S

Height min 57 cm 22,4"
Height max 75 cm 29,5"

Altezza min 57 cm 22,4"
Altezza max 75 cm 29,5"



021

Height min 57 cm 22,4"
Height max 75 cm 29,5"

Altezza min 57 cm 22,4"
Altezza max 75 cm 29,5"



035/S

Height min 57 cm 22,4"
Height max 75 cm 29,5"

Altezza min 57 cm 22,4"
Altezza max 75 cm 29,5"



035

Height min 57 cm 22,4"
Height max 75 cm 29,5"

Altezza min 57 cm 22,4"
Altezza max 75 cm 29,5"

Stools with hydraulic lift and aluminium base / Sgabelli con pompa idraulica e base in alluminio



040/S

Height min 57 cm 22,4"
Height max 73 cm 28,8"

Altezza min 57 cm 22,4"
Altezza max 73 cm 28,8"



040

Height min 57 cm 22,4"
Height max 73 cm 28,8"

Altezza min 57 cm 22,4"
Altezza max 73 cm 28,8"



010/S

Height min 57 cm 22,4"
Height max 73 cm 28,8"

Altezza min 57 cm 22,4"
Altezza max 73 cm 28,8"



010

Height min 57 cm 22,4"
Height max 73 cm 28,8"

Altezza min 57 cm 22,4"
Altezza max 73 cm 28,8"

LAMPS LAMPADRE

**COD. 854
LED LAMP
DERMATOLOGY 7W**

Flexible arm L. 114 cm
Braccio flessibile L. 114 cm



**COD. 1059
LED LAMP
GYNO 10°**

Flexible arm L. 100 cm
Braccio flessibile L. 100 cm





SCAN THE QR CODE AND
DOWNLOAD ALL OUR CATALOGUES

SCANSIONA IL QR CODE E
SCARICA TUTTI I NOSTRI CATALOGHI

CREDITS

Photo
Maurizio Marcato
Matteo Blaschich

2022

Lemi[®]
ITALIAN WELLNESS EQUIPMENT

Brusaferri & C. srl

Via Mara Maretti Soldi, 13 - 26011 Casalbuttano (CR) Italy

+039 0374 363069 - info@lemigroup.it

www.lemimd.com



443.090.V

MEDICAL & PODIATRY

Lemi[®]
ITALIAN WELLNESS EQUIPMENT

www.lemi.it